

WHEEL ALIGNMENT SPECIFICATIONS & PROCEDURES

2001 Chevrolet Camaro

2000-01 WHEEL ALIGNMENT
Specifications & Procedures

Cars - Except Saturn

IDENTIFICATION

MODEL IDENTIFICATION

| Body Code (1) | Model |
|---------------|---|
| "C" | Park Avenue |
| "E" | Eldorado |
| "F" | Camaro & Firebird |
| "G" | Aurora |
| "H" | Bonneville & LeSabre |
| "J" | Cavalier & Sunfire |
| "K" | DeVille & Seville |
| "M" | Metro |
| "N" | Alero, Grand Am & Malibu |
| "S" | Prizm |
| "V" | Catera |
| "W" | Century, Grand Prix, Impala, Intrigue, Lumina, Monte Carlo & Regal |
| "Y" | Corvette |

(1) - Vehicle body code is fourth character of VIN.

RIDE HEIGHT ADJUSTMENT

NOTE: Proper ride height is necessary for correct wheel alignment. Check ride height with vehicle on level floor. Ensure less than 15.5 lbs. of weight is in trunk (other than spare and tools), fuel tank is full (unless specified otherwise), front seats are in full rearward position and tires are the correct size and properly inflated. Tire inflation specification can be found on door pillar, sidewall of tire, sun visor or in glove box. On vehicles with electronic chassis controls, ensure all systems are functional before adjusting ride height or wheel alignment.

Visually inspect vehicle for signs of abnormal height from front to rear or side to side. If ride height is not within specification, check, repair or replace suspension components.

CHECKING PROCEDURE

"C", "H" & "K" Bodies

1) Ensure Electronic Level Control (ELC) is operating properly (if equipped). Bounce front and rear end of vehicle 3 times. Measure dimension "A" to locate point to measure dimension "J". Measure dimension "J" from underbody points to floor. Measure dimension "Z" between lowest part of ball joint and centerline of control arm bolt. See Fig. 1. See RIDE HEIGHT SPECIFICATIONS ("C", "H" & "K" BODIES) table.

2) Measure dimension "B" to locate point to measure dimension "K". Measure dimension "K" from underbody points to floor. See Fig. 1. Measure dimension "D" between bottom of wheel bearing face and

centerline of outboard control arm bolt. See RIDE HEIGHT SPECIFICATIONS ("C", "H" & "K" BODIES) table.

"E" Body

1) Ensure Electronic Level Control (ELC) is operating properly. Bounce vehicle 3 times at front and rear. Measure dimension "Z" between centerline of front lower control arm bushing bolt and lowest part of ball joint. From the front side of rear suspension, measure dimension "D" between centerline of front inner bearing bushing bolt and centerline of front outer bushing bolt. See Fig. 2. See RIDE HEIGHT SPECIFICATIONS ("E" BODY) table.

2) Measure dimensions "A" and "B" to locate measuring points "J" and "K". Measure dimensions "J", "K", "E" and "F" between underbody and floor and center of wheel well and floor. See Fig. 2. See RIDE HEIGHT SPECIFICATIONS ("E" BODY) table.

"F" Body

Jounce front and rear bumper at least 1.5" (38 mm) and let settle. Measure and note front and rear trim heights. See Fig. 3. Repeat 2 more times. Average measurements for trim heights. See RIDE HEIGHT SPECIFICATIONS ("F" BODY) table.

"G" Body

1) Ensure Electronic Level Control (ELC) is operating properly (if equipped). Bounce front and rear end of vehicle 3 times. Measure dimension "Z" between lowest part of ball joint and centerline of control arm bolt. See Fig. 1. See RIDE HEIGHT SPECIFICATIONS ("G" BODY) table.

2) Measure dimension "D" between bottom of wheel bearing face and centerline of outboard control arm bolt. See Fig. 1. See RIDE HEIGHT SPECIFICATIONS ("G" BODY) table.

"J" Body

1) Push front bumper down about 1.5" (38 mm). Let vehicle settle. Repeat 3 times. Measure dimension "Z". See Fig. 4. See RIDE HEIGHT SPECIFICATIONS ("J" BODY) table.

2) Lift rear bumper up about 1.5" (38 mm). Let vehicle settle. Repeat 2 more times. Measure dimension "D". See Fig. 4. See RIDE HEIGHT SPECIFICATIONS ("J" BODY) table.

3) Measure dimensions "A" and "B" to locate measuring points "J" and "K". Measure dimensions "J" and "K" between underbody and floor, and center of wheel well and floor. See Fig. 4. See RIDE HEIGHT SPECIFICATIONS ("J" BODY) table.

"M" Body

NOTE: Fuel tank must be at least 1/8 full.

1) Lift front bumper about 1.5" (38 mm). Allow vehicle to settle. Push front bumper down about 1.5" (38 mm). Allow vehicle to settle. Measure dimension "J" between centerline of front wheel and floor. See Fig. 4. See RIDE HEIGHT SPECIFICATIONS ("M" BODY) table.

2) Lift rear bumper about 1.5" (38 mm). Allow vehicle to settle. Push rear bumper down about 1.5" (38 mm). Allow vehicle to settle. Measure dimension "K" between centerline of rear wheel and floor. See Fig. 4. See RIDE HEIGHT SPECIFICATIONS ("M" BODY) table.

3) Measure dimension "Z" between centerline of lower control arm rear bolt and bottom of ball joint. See Fig. 4. See RIDE HEIGHT SPECIFICATIONS ("M" BODY) table.

"N" Body

1) Lift front bumper about 1.5" (38 mm) and allow vehicle to settle. Repeat 2 more times. Distance "A" is from center of front axle

to locate point to measure dimension "J". Dimension "J" is measured from floor to bottom of rocker panel. Measure dimension "Z". Dimension "Z" is measured from bottom of ball joint to bottom of frame rail. See Fig. 6. See RIDE HEIGHT SPECIFICATIONS ("N" BODY) table. Note measurements. Do this 2-3 times, and average measurements.

2) Lift rear bumper up about 1.5" (38 mm) and allow vehicle settle. Repeat 2 more times. Distance "B" from center of rear axle to locate point to measure dimension "K". Dimension "K" is measured from floor to bottom of rocker panel. See Fig. 6. See RIDE HEIGHT SPECIFICATIONS ("N" BODY) table. Push rear bumper down about 1.5" (38 mm) and allow vehicle to rise. Repeat 2 more times. Measure dimension "K" again. Average high and low measurements to determine true ride height.

"S" Body

NOTE: Fuel tank must be at least 1/8 full.

1) Lift front bumper 1.5" (38 mm) and let settle. Repeat 2 more times. Push front bumper down 1.5" (38 mm) and let settle. Repeat 2 more times. Measure dimension "Z" between center of lower control arm mounting bolt and floor. See Fig. 7. See RIDE HEIGHT SPECIFICATIONS ("S" BODY) table.

2) Lift rear bumper 1.5" (38 mm) and let settle. Repeat 2 more times. Push rear bumper down 1.5" (38 mm) and let settle. Repeat 2 more times. Measure dimension "D" between center of rear trailing arm bolt and floor. See Fig. 7. See RIDE HEIGHT SPECIFICATIONS ("S" BODY) table.

"V" Body

1) Ensure Automatic Level Control (ALC) is operative while taking measurements. Lift front bumper 1.5" (38 mm) and let settle. Repeat 2 more times. Push front bumper down 1.5" (38 mm) and let settle. Repeat 2 more times. Measure dimensions "J" and "P". Dimension "J" is measured from bottom of rocker panel to floor. Dimension "P" is measured from top of tire to bottom of front tire (diameter). See Fig. 8. See RIDE HEIGHT SPECIFICATIONS ("V" BODY) table.

2) Lift rear bumper 1.5" (38 mm) and let settle. Repeat 2 more times. Push rear bumper down 1.5" (38 mm) and let settle. Repeat 2 more times. Measure dimensions "K" and "R". Dimension "K" is measured from bottom of rocker panel to floor. Dimension "R" is measured from top of tire to bottom of rear tire (diameter). See Fig. 8. See RIDE HEIGHT SPECIFICATIONS ("V" BODY) table.

"W" Body

1) Lift front bumper 1.5" (38 mm) and let settle. Push front bumper down 1.5" (38 mm) and allow vehicle to rise and settle. Measure dimension "Z" between center of rear bushing bolt and lowest point of ball joint. See Fig. 9. Measure dimension "A" from center of front wheel to locate point to measure dimension "J". Measure dimension "J" between lower rocker panel to floor. See RIDE HEIGHT SPECIFICATIONS ("W" BODY) table. If ride height is not within specification, replace damaged or worn suspension parts.

2) Lift rear bumper 1.5" (38 mm) and let settle. Push rear bumper down 1.5" (38 mm) and allow vehicle to rise and settle. On Lumina, measure dimension "D" from a point 2.17" (55 mm) from outboard of rear brake hose bracket bolt centerline to trailing arm to knuckle attachment bolt centerline. On all other models, measure dimension "D" from a point 1.18" (30 mm) from outboard of rear brake hose bracket bolt centerline to trailing arm to knuckle attachment bolt centerline. See Fig. 9.

3) Measure dimension "B" to locate point to measure dimension "K". Measure dimension "K" between from bottom of rocker panel to

floor. See Fig. 9. See RIDE HEIGHT SPECIFICATIONS ("W" BODY) table. If ride height is not within specification, repair or replace damaged or worn suspension parts.

"Y" Body (Front)

NOTE: When taking measurements, the real time damping system must be operative during procedure. If ride height adjustment is necessary, opposite trim height will be affected. Recheck vehicles ride height after each adjustment.

1) Lift front bumper 1.5" (38 mm) and let settle. Repeat 2 more times. Push front bumper down 1.5" (38 mm) and let settle. Repeat 2 more times. Measure from center of front axle to lower edge of rocker panel (dimension "A") to locate dimension "J" measuring point. Measure dimension "J" from bottom of rocker panel to floor. See Fig. 10. See RIDE HEIGHT SPECIFICATIONS ("Y" BODY) table. If front ride height is not within specification, go to step 3).

2) Using Trim Height Measurement Gauge (J-42854), measure left and right side dimension "Z" between lowest point of ball joint and center of lower control arm mounting bolt. See Fig. 10. See RIDE HEIGHT SPECIFICATIONS ("Y" BODY) table. If ride height is not within specification, go to next step.

3) If ride height adjustment is necessary, Trim Height Adjustment Tool (J-42743) must be used to prevent damage to rubber shear pad on end of adjuster bolt. See Fig. 11. Adjust dimension "Z" by turning the spring adjuster bolt. One complete turn of adjuster bolt equals about 0.08" (2 mm). Remove trim height adjustment tool. Ensure maximum difference between left and right spring adjuster bolt gaps does not exceed 0.196" (5 mm). Recheck ride height. Measure and adjust front spring adjuster bolt gaps. Bolt gaps should be between 0.078-0.944 (2-24 mm). See Fig. 12.

"Y" Body (Rear)

NOTE: When taking measurements, the real time damping system must be operative during procedure. If ride height adjustment is necessary, the opposite trim height adjustment will be affected. Recheck vehicles ride height after each adjustment.

1) Lift rear bumper 1.5" (38 mm) and let settle. Repeat 2 more times. Push rear bumper down 1.5" (38 mm) and let settle. Repeat 2 more times. Measure from center of rear axle to lower edge of rocker panel (dimension "B") to locate dimension "K" measuring point. Measure dimension "K" from bottom of rocker panel to floor. See Fig. 10. See RIDE HEIGHT SPECIFICATIONS ("Y" BODY) table. If rear ride height is not within specification, go to step 3).

2) Using Trim Height Measurement Gauge (J-42854), measure left and right side dimension "D" between lowest point of ball joint and center of lower control arm mounting bolt. See Fig. 10. See RIDE HEIGHT SPECIFICATIONS ("Y" BODY) table. If ride height is not within specification, go to next step.

3) If ride height adjustment is necessary, adjust dimension "D" by removing spring bolt retainers and turning the spring adjuster bolt. One complete turn of adjuster bolt equals about 0.08" (2 mm). Ensure maximum difference between rear spring stud height does not exceed 0.196" (5 mm). See Fig. 13. Recheck ride height. Measure and adjust front spring adjuster bolt gaps. Rear spring stud height should be between 0.866-1.811" (22-46 mm). Install retainers to bolts.

RIDE HEIGHT SPECIFICATIONS

On "C", "G", "H", and "J" Bodies, maximum variation between

side-to-side and front-to-rear should not exceed .75" (19 mm). On "N" Body, maximum variation between side-to-side should not exceed 0.24" (6 mm). On all other models, maximum variation between side-to-side and front-to-rear should not exceed .47" (12 mm).

RIDE HEIGHT SPECIFICATIONS ("C", "H" & "K" BODIES)

| Application | In. (mm) |
|---|---------------------|
| Bonneville, DeVille, LeSabre, Park Avenue & Seville (1) | |
| Dimension "A" | 23.5 (600) |
| Dimension "B" | 23.22 (590) |
| Dimension "J" | 6.44-7.25 (164-184) |
| Dimension "K" | 8.38-9.19 (213-233) |
| Dimension "Z" | 1.19-2.0 (30-50) |
| Dimension "D" | 3.0-3.75 (79-96) |

(1) - See Fig. 1.

RIDE HEIGHT SPECIFICATIONS ("E" BODY)

| Application | In. (mm) |
|---------------------|-------------|
| Eldorado (1) | |
| Dimension "A" | 22.84 (580) |
| Dimension "B" | 22.17 (563) |
| Dimension "J" | 8.66 (220) |
| Dimension "K" | 8.43 (214) |
| Dimension "E" | 28.15 (715) |
| Dimension "F" | 27.91 (709) |
| Dimension "Z" | 1.97 (50) |
| Dimension "D" | 1.14 (29) |

(1) - See Fig. 2.

RIDE HEIGHT SPECIFICATIONS ("F" BODY)

| Application | In. (mm) |
|---|------------|
| Camaro & Firebird (1) | |
| Dimension "1" (Side Rocker Panel) | 8.0 (204) |
| Dimension "2" (Side Rocker Panel) | 8.2 (208) |
| Dimension "3" (Front Fascia) | |
| Camaro | 17.4 (443) |
| Firebird With 235/55 Tires | 13.4 (342) |
| Trans Am Except Base Model | 13.4 (342) |
| Trans Am Base Model | 16.3 (416) |
| Dimension "4" (Rear Fascia) | |
| Camaro | 14.4 (367) |
| Firebird & Trans Am | 14.7 (375) |

(1) - See Fig. 3.

RIDE HEIGHT SPECIFICATIONS ("G" BODY)

| Application | In. (mm) |
|---------------------|-----------------|
| Aurora (1) | |
| Dimension "D" | 3.0-3.8 (76-96) |

Dimension "Z" 1.2-2.0 (30-50)

(1) - See Fig. 1.

RIDE HEIGHT SPECIFICATIONS ("J" BODY)

| Application | In. (mm) |
|------------------------|----------------|
| Cavalier & Sunfire (1) | |
| Dimension "A" | 31 (800) |
| Dimension "B" | 22 (560) |
| Dimension "J" | 87 (223) |
| Dimension "K" | 9 (230) |
| Dimension "Z" | |
| With 14" Tires | 0.16 (4) |
| With 15" Tires | |
| 2.2L (2) | 0 (0) |
| 2.4L (3) | - 0.08 (- 2.0) |
| 2.4L (4) | 0.4 (1.0) |

- (1) - See Fig. 4.
(2) - With active suspension.
(3) - With ride handling suspension.
(4) - With soft ride suspension.
-

RIDE HEIGHT SPECIFICATIONS ("M" BODY)

| Application | In. (mm) |
|---------------------|-------------|
| Metro (1) | |
| Dimension "A" | 17.75 (450) |
| Dimension "B" | 17.75 (450) |
| Dimension "J" | 8.25 (210) |
| Dimension "K" | 8.85 (225) |
| Dimension "Z" | 1.75 (45) |

(1) - See Fig. 4.

RIDE HEIGHT SPECIFICATIONS ("N" BODY)

| Application | In. (mm) |
|---------------------|------------|
| Alero (1) | |
| Dimension "A" | 32.2 (817) |
| Dimension "B" | 25.0 (635) |
| Dimension "J" | 9.33 (237) |
| Dimension "K" | 9.61 (244) |
| Dimension "D" | |
| 15" Wheels | 4.84 (123) |
| 16" Wheels | 4.72 (120) |
| Dimension "Z" | |
| 15" Wheels | 0 (0) |
| 16" Wheels | - 5 (- 20) |
| Grand Am (1) | |
| Dimension "A" | 32.2 (817) |
| Dimension "B" | 25.0 (635) |
| Dimension "J" | 9.33 (237) |
| Dimension "K" | 9.61 (244) |
| Dimension "D" | |
| 15" Wheels | 0 (0) |

| | |
|---------------|------------|
| 16" Wheels | 4.72 (120) |
| Dimension "Z" | |
| 15" Wheels | 0 (0) |
| 16" Wheels | - 5 (- 20) |
| Malibu (1) | |
| Dimension "A" | 32.2 (817) |
| Dimension "B" | 25.0 (635) |
| Dimension "J" | 9.33 (237) |
| Dimension "K" | 9.61 (244) |
| Dimension "D" | 4.84 (123) |
| Dimension "Z" | 0 (0) |

(1) - See Fig. 6.

RIDE HEIGHT SPECIFICATIONS ("S" BODY)

| Application | In. (mm) |
|-----------------------|----------------------------|
| Prizm (1) | |
| Dimension "Z" | |
| With P175/64R14 Tires | 6.88 To 7.68 (175 To 195) |
| With P185/64R14 Tires | 7.08 To 7.88 (180 To 200) |
| Dimension "D" | |
| With P175/64R14 Tires | 9.25 To 10.05 (235 To 255) |
| With P185/64R14 Tires | 9.44 To 10.24 (240 To 260) |

(1) - See Fig. 7

RIDE HEIGHT SPECIFICATIONS ("V" BODY)

| Application | In. (mm) |
|---------------|------------|
| Catera (1) | |
| Dimension "P" | 27.3 (693) |
| Dimension "J" | 6.9 (175) |
| Dimension "K" | 6.5 (165) |
| Dimension "R" | 27.3 (693) |

(1) - See Fig. 8.

RIDE HEIGHT SPECIFICATIONS ("W" BODY)

| Application | In. (mm) |
|----------------------|-------------|
| Except Lumina (1) | |
| Dimension "A" | 23.8 (605) |
| Dimension "B" | 20.7 (526) |
| Dimension "J" & "K" | 8.4 (213.3) |
| Dimension "Z" | |
| With 225/60R16 Tires | 1.89 (48) |
| With 225/70R15 Tires | 2.13 (55) |
| Dimension "D" | |
| With 225/60R16 Tires | 10.4 (255) |
| With 225/70R15 Tires | 10.3 (261) |
| Lumina (1) | |
| Dimension "A" | 23.8 (605) |
| Dimension "B" | 20.7 (525) |
| Dimension "J" & "K" | 8.4 (213.3) |
| Dimension "Z" | |
| With 205/70R15 Tires | 2.13 (55) |

| | |
|----------------------------|-------------|
| With 225/60R16 Tires | 1.89 (48) |
| Dimension "D" | |
| With 205/70R15 Tires | 10.28 (261) |
| With 225/60R16 Tires | 10.04 (255) |

(1) - See Fig. 9.

RIDE HEIGHT SPECIFICATIONS ("Y" BODY)

| Application | In. (mm) |
|---------------------|-------------------------|
| Corvette (1) | |
| Dimension "A" | 35 (889) |
| Dimension "B" | 31 (787) |
| Dimension "J" | 6.02 (153) |
| Dimension "K" | 6.22 (158) |
| Dimension "D" | 4.0 To 4.5 (102 To 114) |
| Dimension "Z" | 1.48 To 1.99 (38 To 50) |

(1) - See Fig. 10.

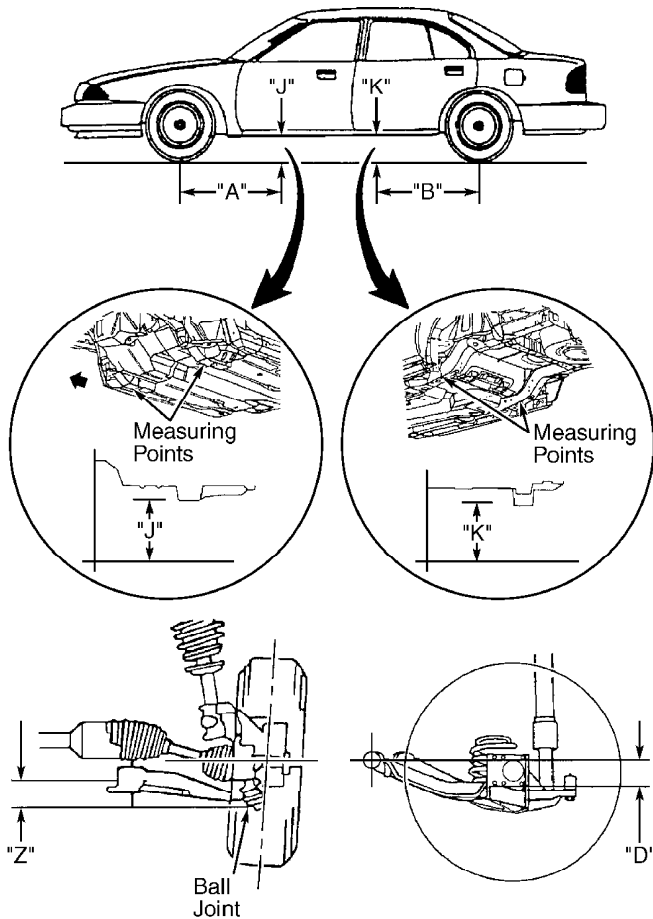

G99C03212
 Fig. 1: Ride Height Measuring Points ("C", "G", "H" & "K" Bodies)
 Courtesy of General Motors Corp.

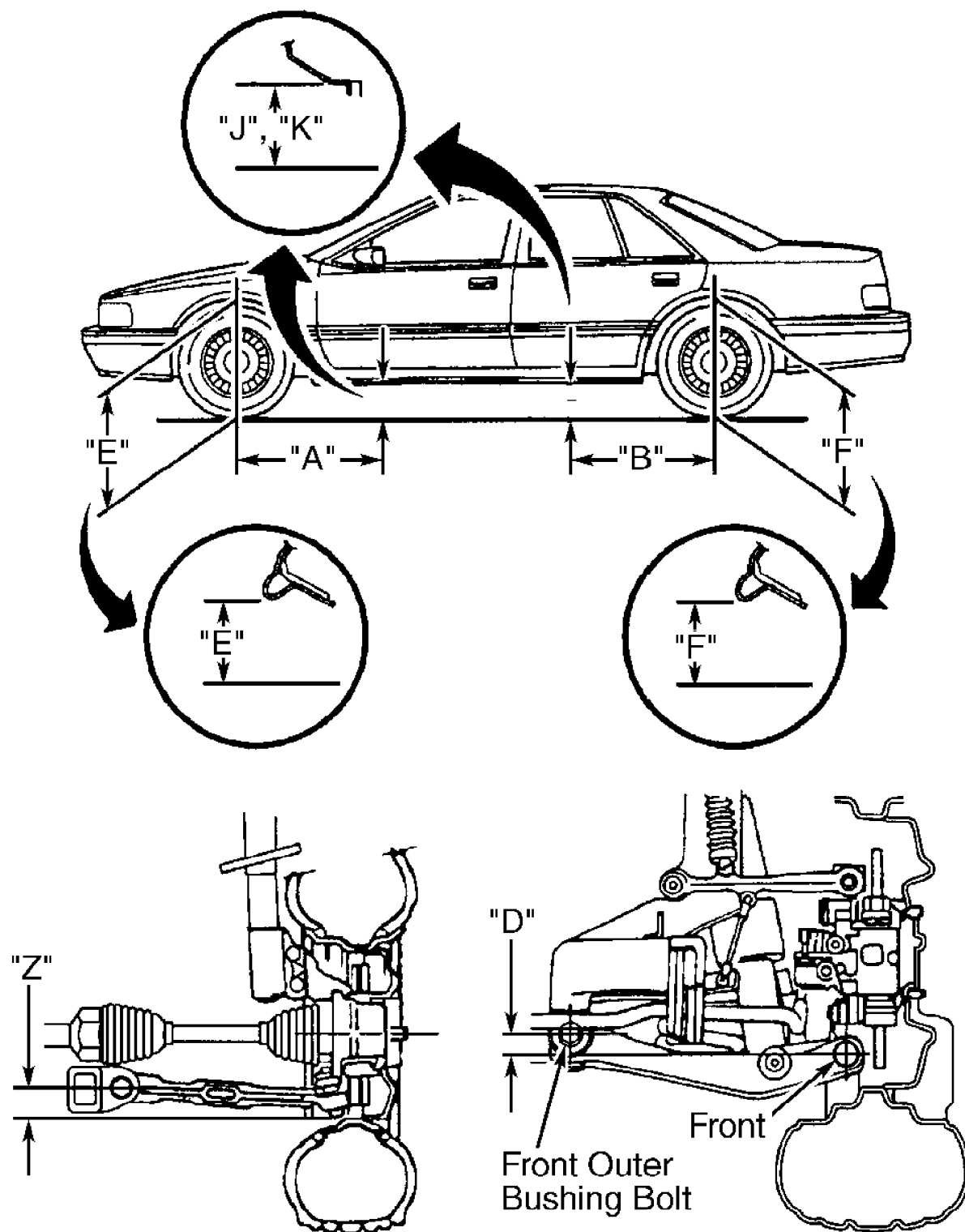

G99J03215

Fig. 2: Ride Height Measuring Points ("E" Body)
 Courtesy of General Motors Corp.

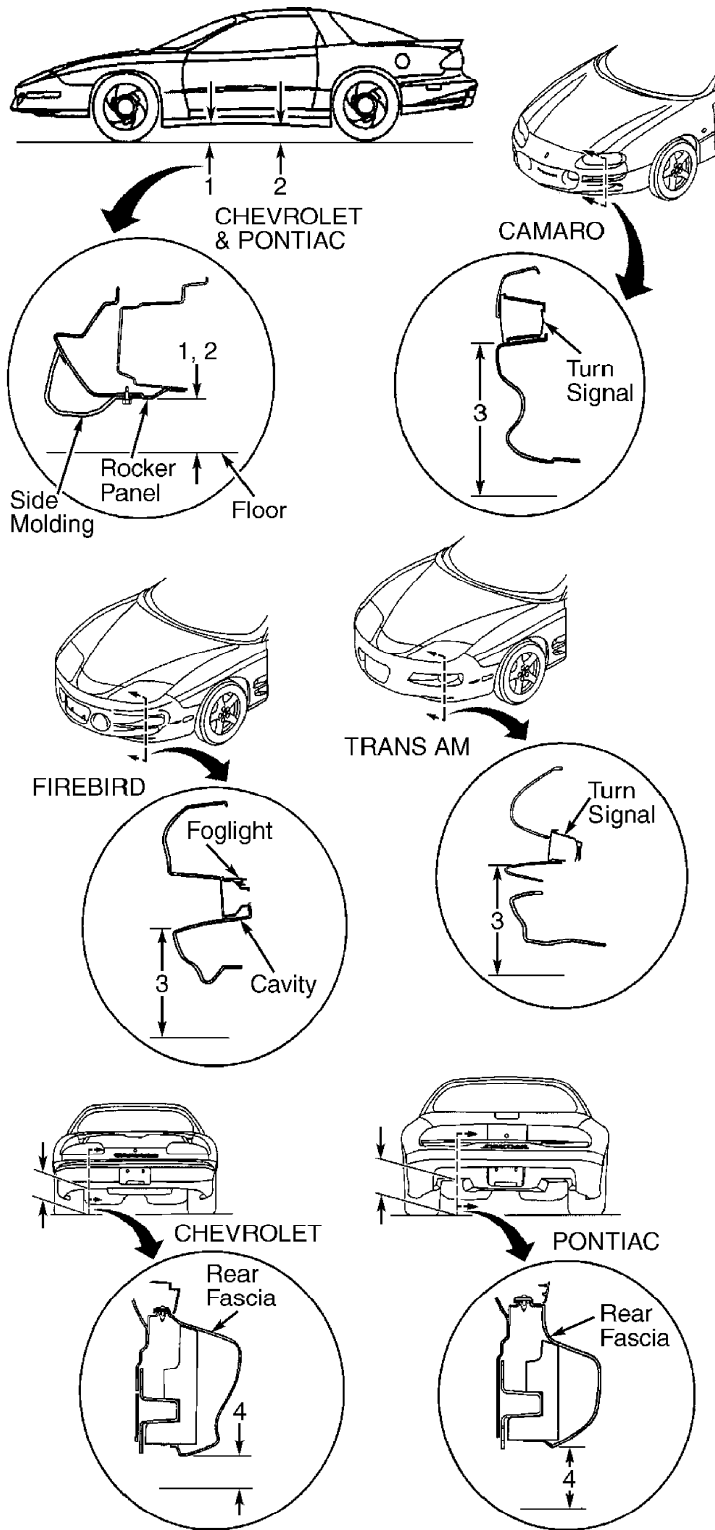

G99B03396

Fig. 3: Ride Height Measuring Points ("F" Body)
 Courtesy of General Motors Corp.

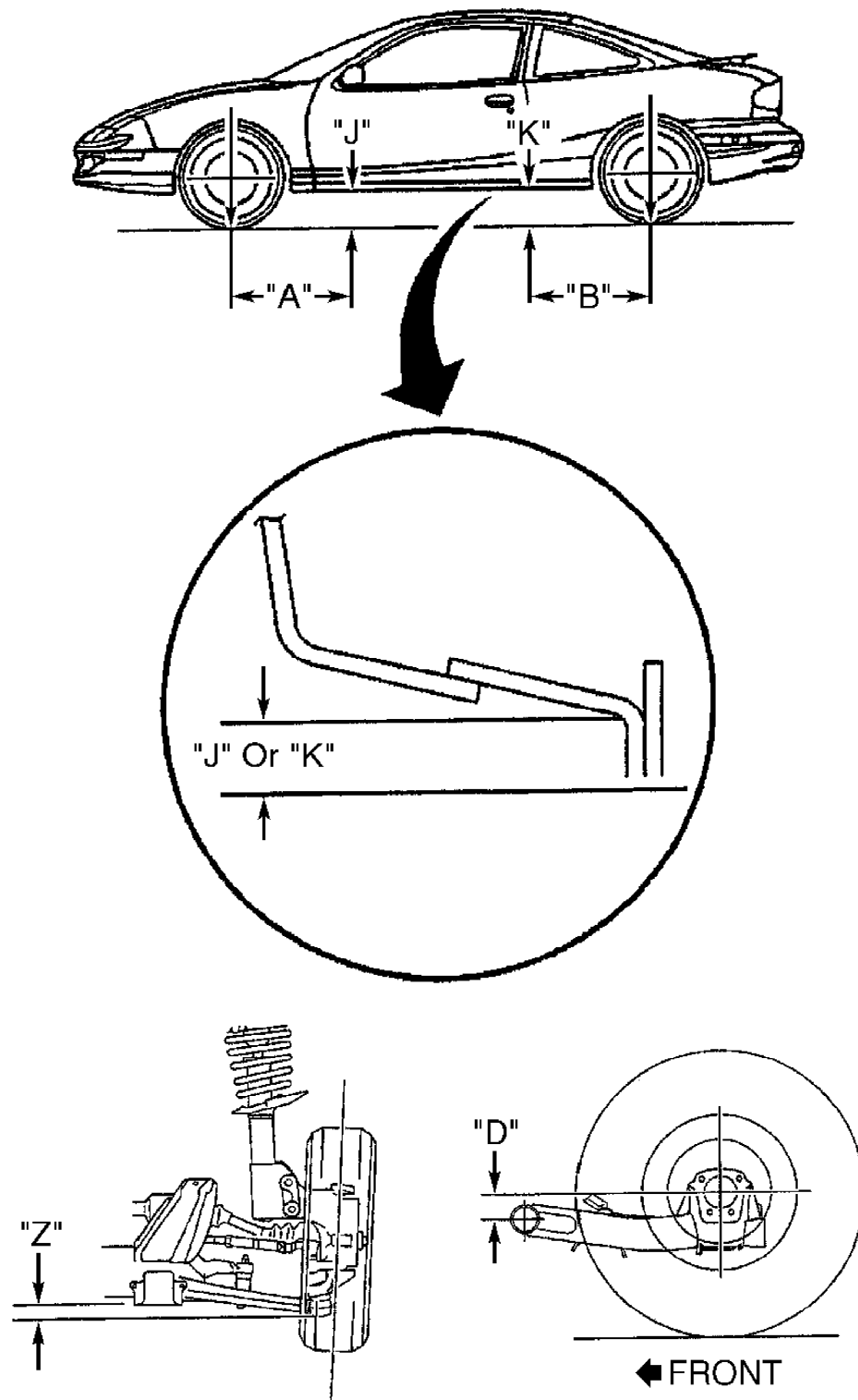

G00005687

Fig. 4: Ride Height Measuring Points ("J" Body)
 Courtesy of General Motors Corp.

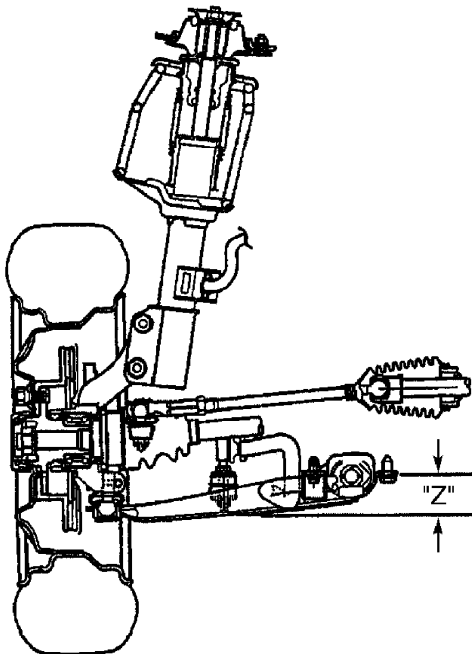
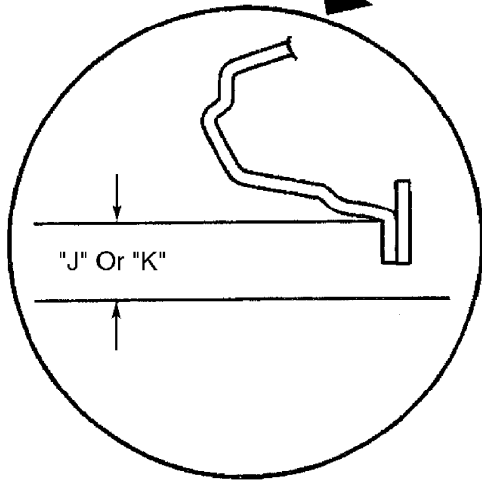
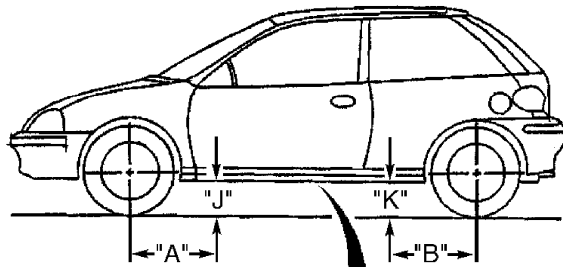

G00005688

Fig. 5: Ride Height Measuring Points ("M" Body)
Courtesy of General Motors Corp.

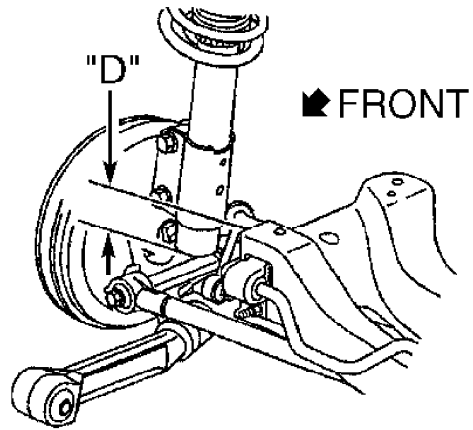
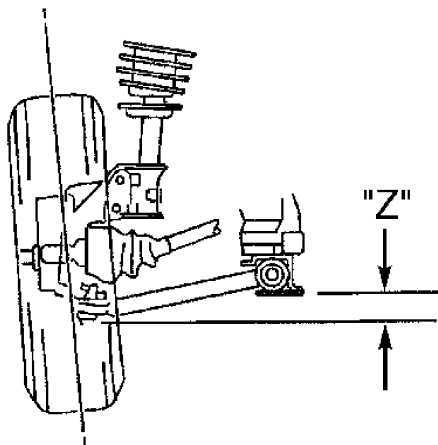
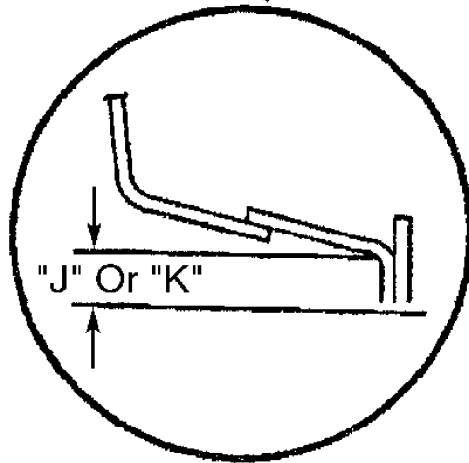
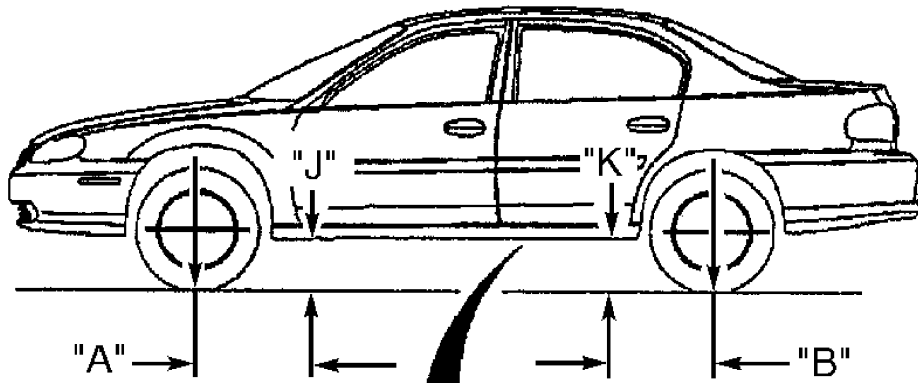

G00005689

Fig. 6: Ride Height Measuring Points ("N" Body)
 Courtesy of General Motors Corp.

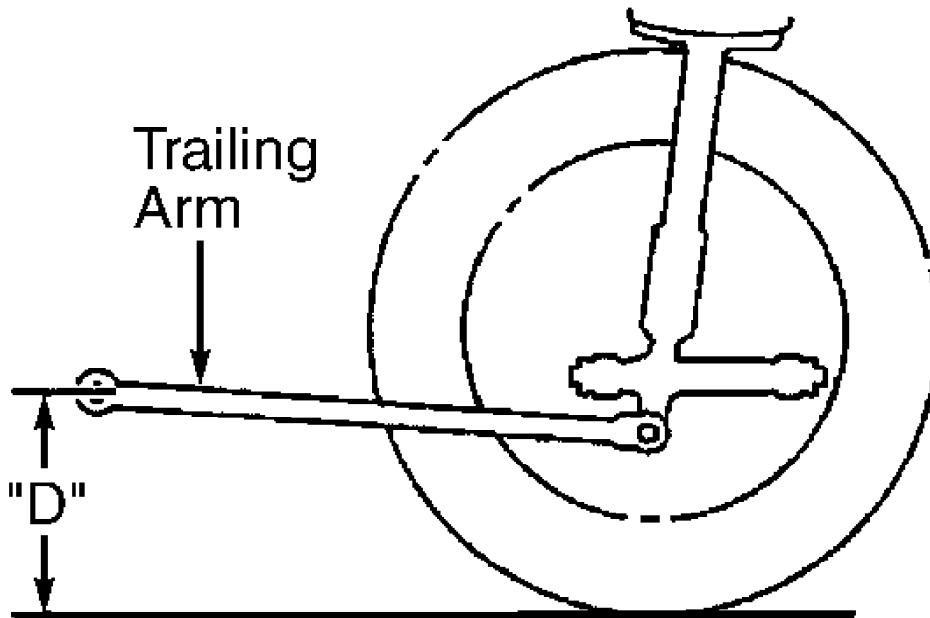
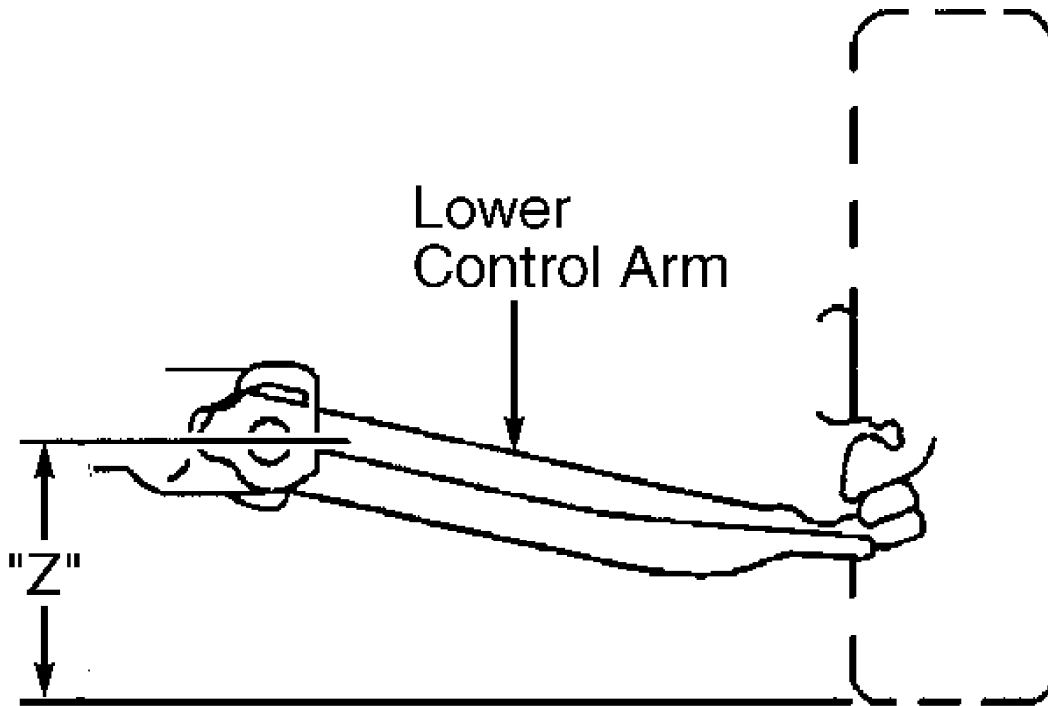

G99J03220

Fig. 7: Ride Height Measuring Points ("S" Body)
Courtesy of general motor corp.

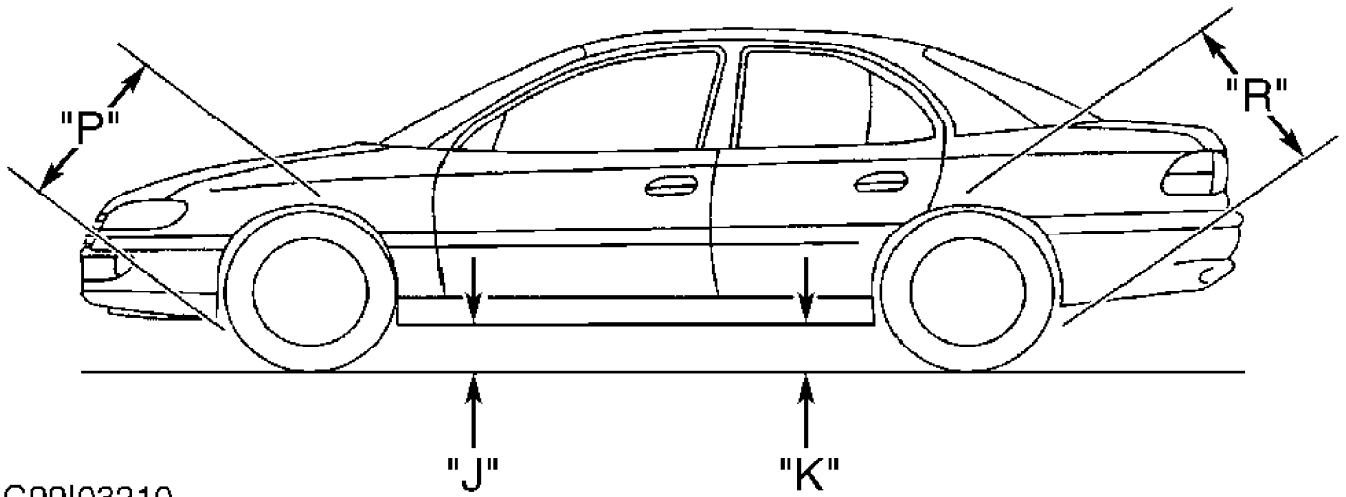

G99103210

Fig. 8: Ride Height Measuring Points ("V" Body)
 Courtesy of General Motors Corp.

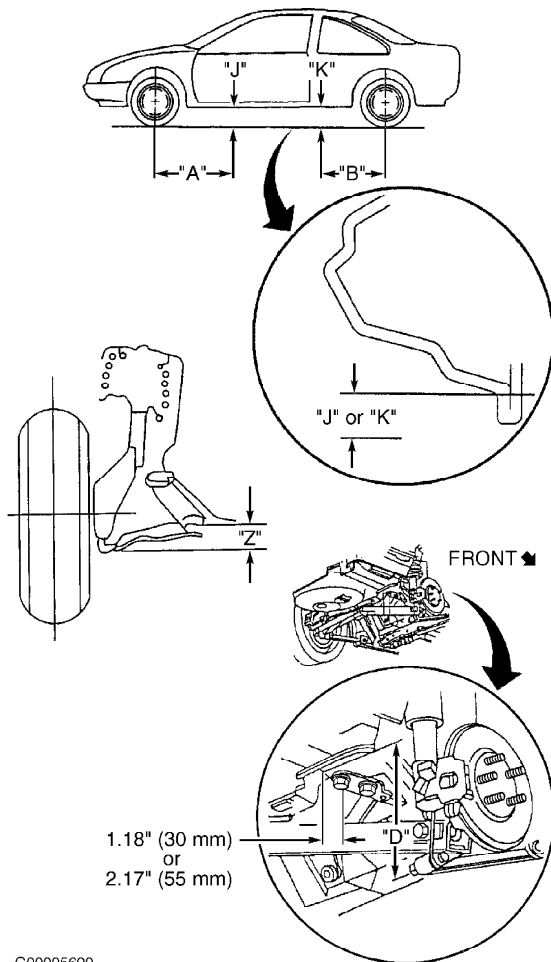

G00005690

Fig. 9: Ride Height Measuring Points ("W" Body)
 Courtesy of General Motors Corp.

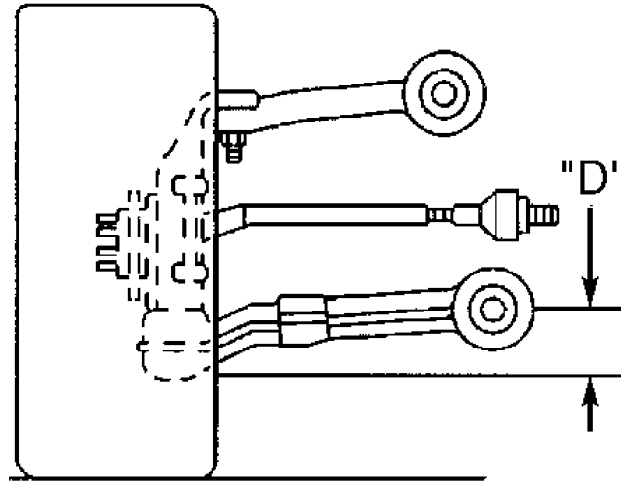
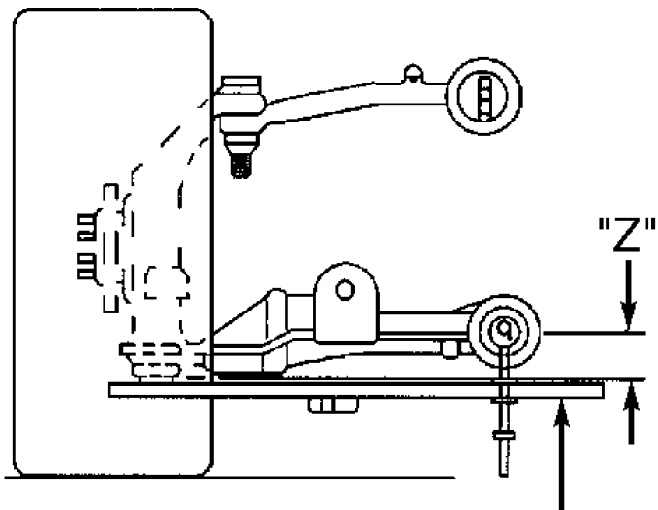
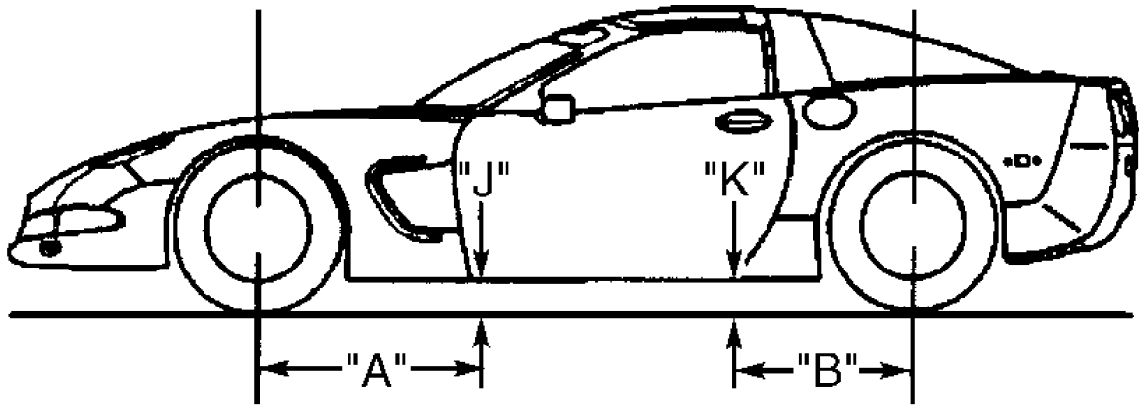

Trim Height
Measurement
Gauge

G99F03398

Fig. 10: Ride Height Measuring Points ("Y" Body)
Courtesy of General Motors Corp.

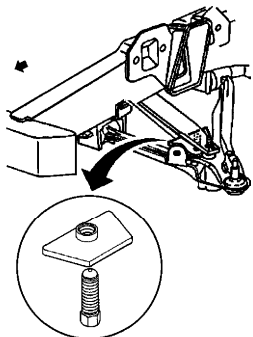

TRIM HEIGHT
ADJUSTMENT TOOL

G99I03205

Fig. 11: Installing Trim Height Adjustment Tool ("Y" Body)
Courtesy of General Motors Corp.

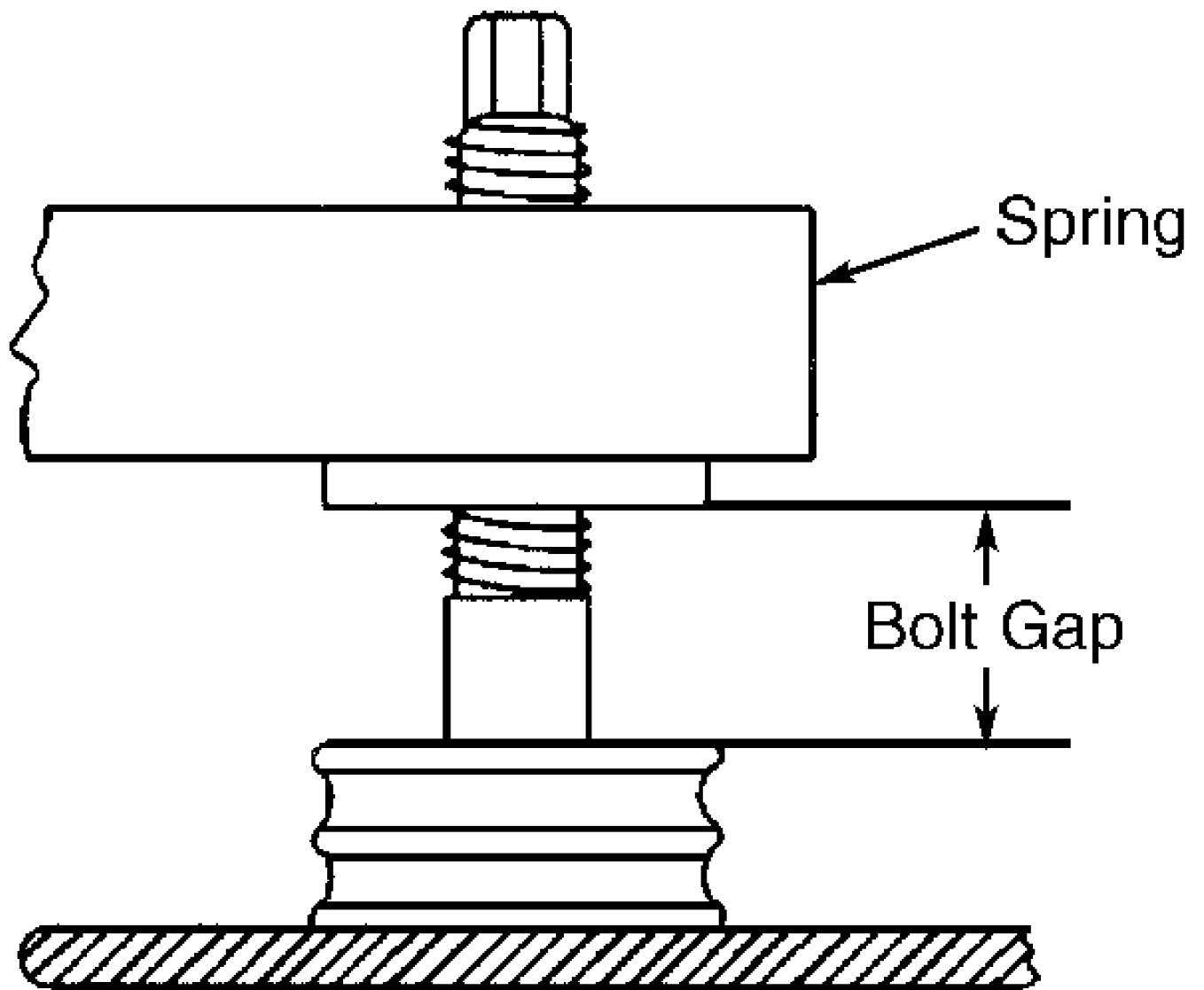

G99H03399

Fig. 12: Measuring Front Spring Adjuster Bolt Gap ("Y" Body)
 Courtesy of General Motors Corp.

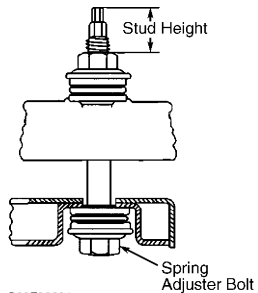

G99F03204
 Fig. 13: Measuring Rear Spring Stud Height ("Y" Body)
 Courtesy of genral motors corp.

FLOOR JACK

FWD Vehicles

When supporting vehicle using floor jack, place support at suspension lift points or frame lift points. Floor jacks may be placed under front crossmember on most models. See Figs. 14-21.

RWD Vehicles

Floor jack may be used under rear axle or front suspension lower control arms. Observe the following precautions:

- * DO NOT use jack on any part of underbody.
- * DO NOT raise entire vehicle at side rail with jack midway between front and rear wheels, or permanent body damage may result.
- * DO NOT allow lifting plate fingers to contact axle cover plate when lifting at rear axle housing.
- * If vehicle is equipped with a stabilizer bar, DO NOT lift at rear axle housing. See Figs. 14-21.

BUMPER JACK

Bumper jack, if supplied as original equipment with vehicle, should only be used to change a flat tire. If vehicle is not supplied with a bumper jack, DO NOT lift vehicle by the bumper at any time.

AXLE CONTACT HOIST

NOTE: Always follow hoist manufacturer's instructions. DO NOT allow hoist or adapters to contact suspension, exhaust or steering components. Frame contact must be made. Use adapters if necessary.

Hoist should contact lower control arms, or front crossmember and rear axle.

FRAME CONTACT HOIST

Hoist adapters must contact vehicle in specified areas. See Figs. 14-21. Adapters must be positioned to distribute load and support vehicle in a stable manner. DO NOT allow lift pads to contact body panels or exhaust system components.

WARNING: If removing rear axle, fuel tank, spare tire or liftgate using single-post hoist, anchor vehicle to hoist. Place jack stands under vehicle, or add weight on rear end of vehicle to prevent tipping when center of gravity changes.

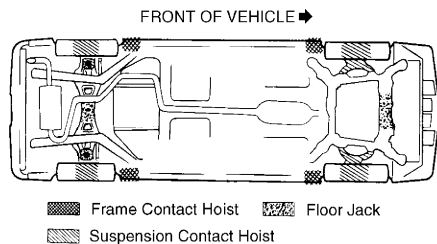

G95E14609

Fig. 14: Lifting Points ("C", "G" & "H" Bodies)
Courtesy of General Motors Corp.

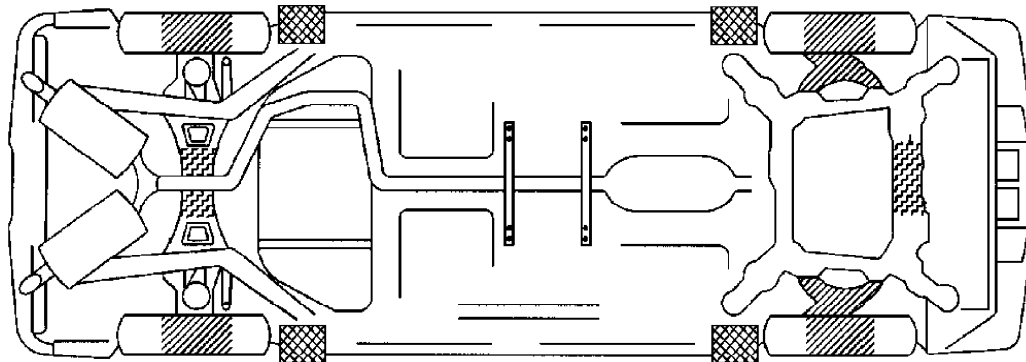

1999 "K" BODIES (EXCEPT SEVILLE)

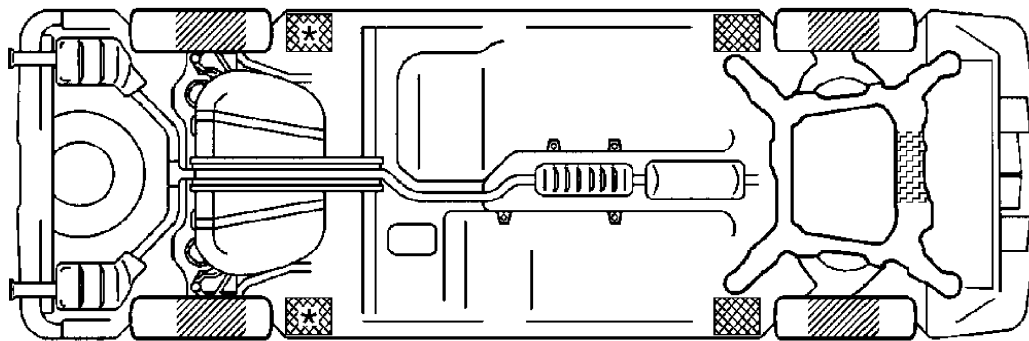

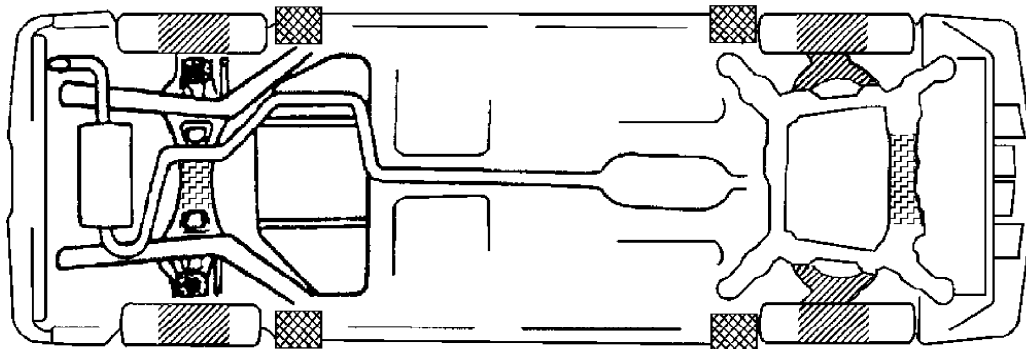

* Lifting point for both Suspension Frame Contact & Floor Hoist.

1999 SEVILLE



1998 SEVILLE, 1998-99 "J" BODY & METRO

-  Frame Contact Hoist
-  Floor Jack
-  Suspension Or Drive-On Hoist

G99G03214
 Fig. 15: Lifting Points ("E" & "K" Bodies)
 Courtesy of General Motors Corp.

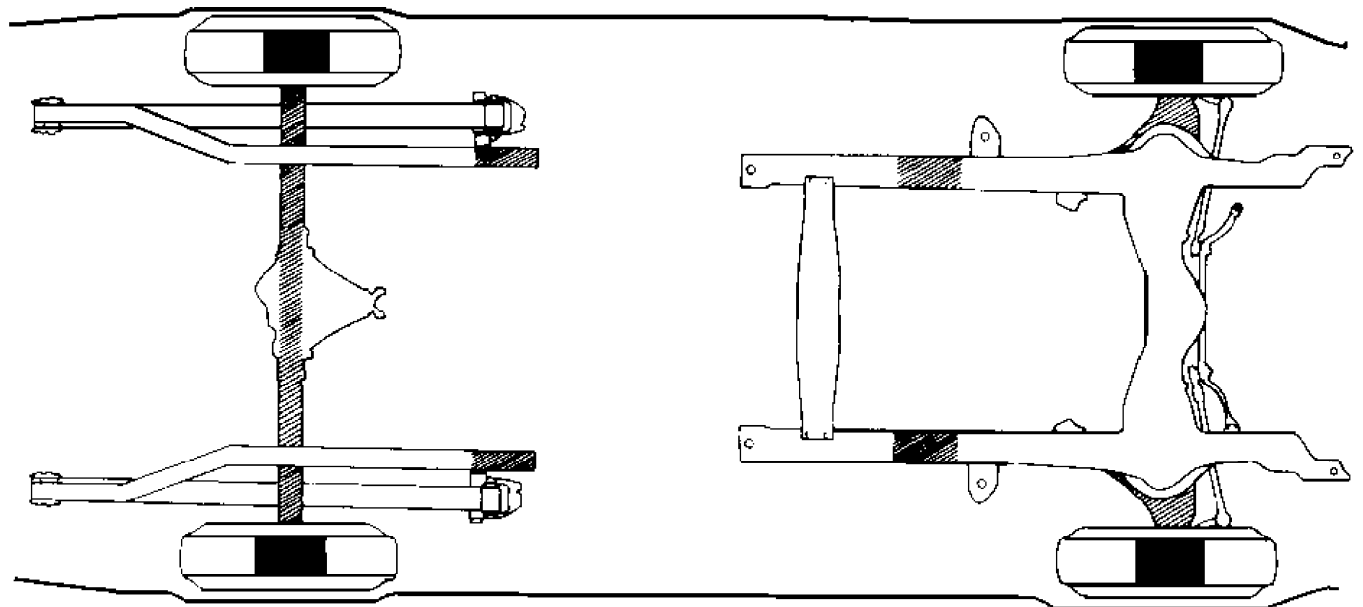

■ Drive-On Hoist

▨ Floor Jack Or Axle Contact Hoist

G95A14613

Fig. 16: Lifting Points ("F" Body)
 Courtesy of General Motors Corp.

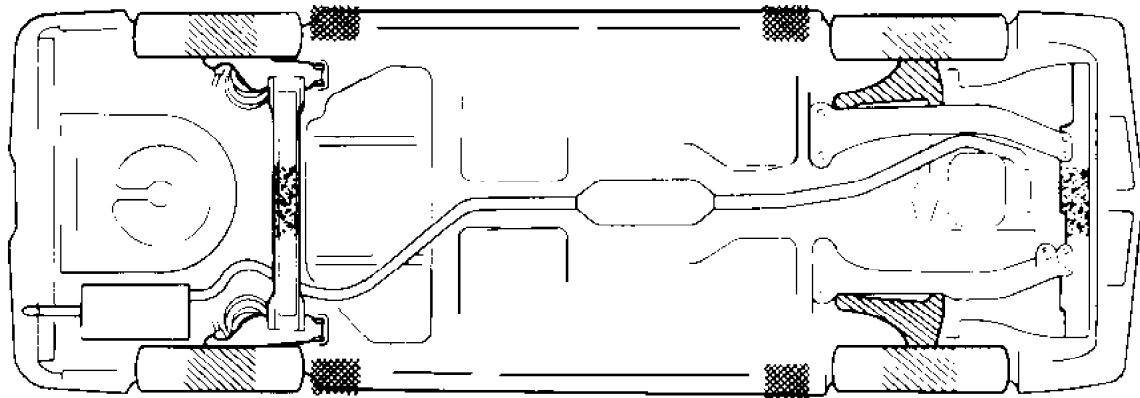

▩ Floor Jack



▨ Frame Contact Hoist

▨ Suspension Contact Hoist

G95C14615

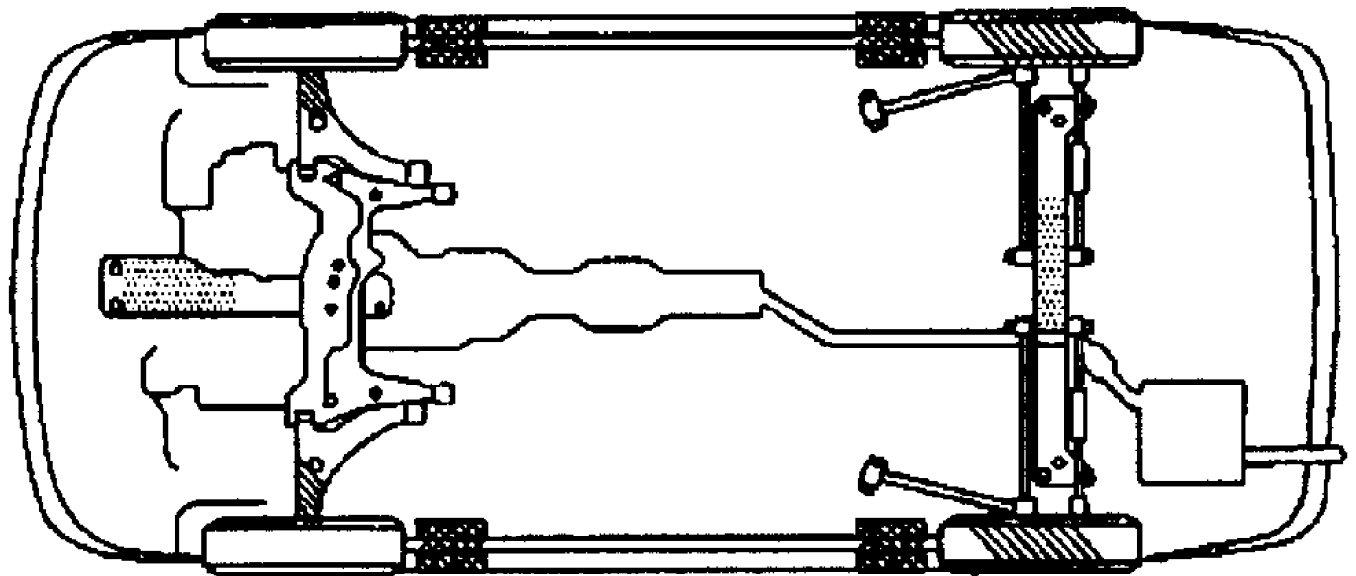
Fig. 17: Lifting Points ("J" & "N" Bodies)
 Courtesy of General Motors Corp.



-  Frame Contact Hoist
-  Floor Jack
-  Suspension Contact Hoist

G99H03219

Fig. 18: Lifting Points ("M" & "S" Bodies)
 Courtesy of General Motors Corp.

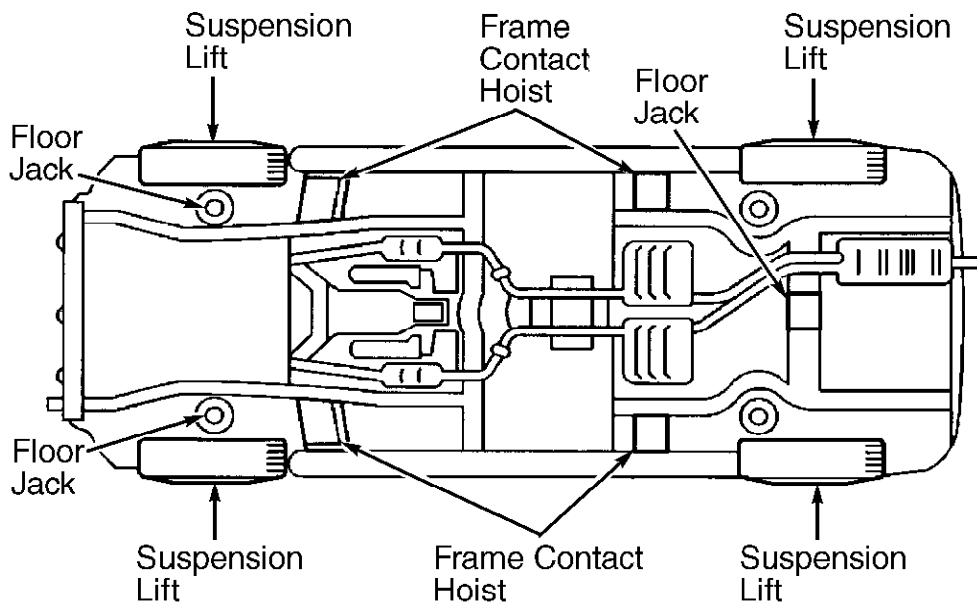

G99A03211



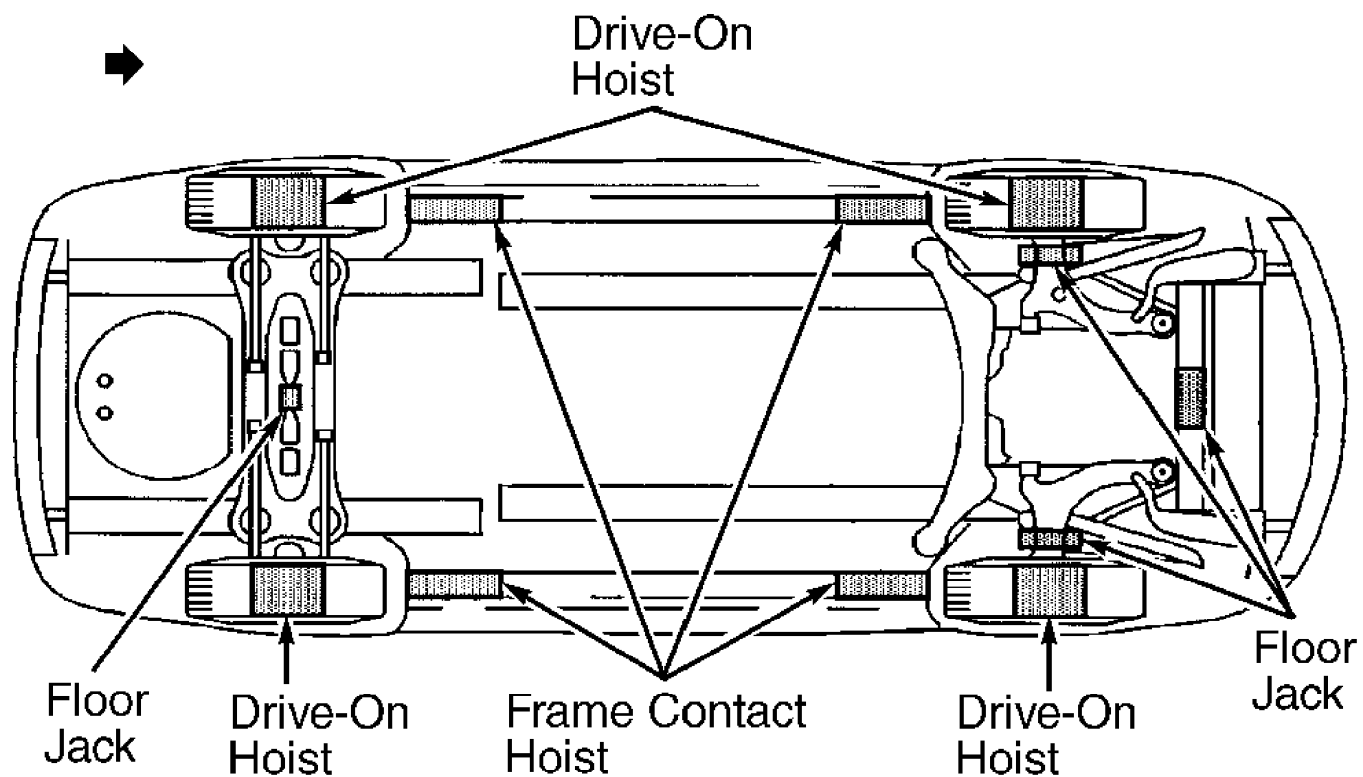

Fig. 19: Lifting Points ("V" Body)
 Courtesy of General Motors Corp.

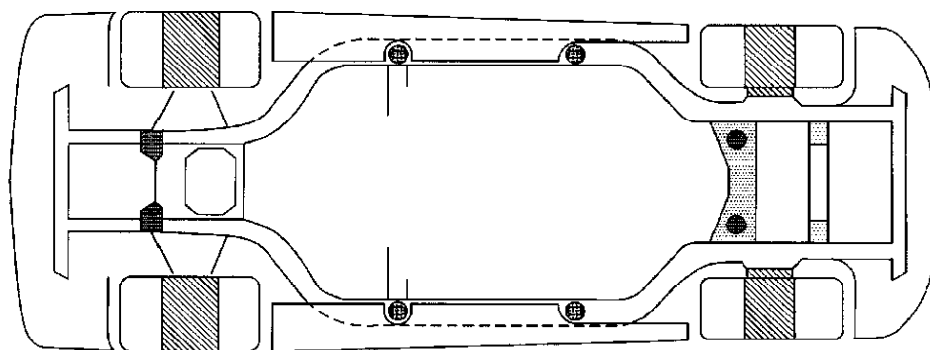

G99D03217

Fig. 20: Lifting Points ("W" Body)
 Courtesy of General Motors Corp.



-  Preferred Vehicle Jacking Locations
-  Optional Vehicle Jacking Locations
-  Frame Contact Hoist Locations, Optional Vehicle Jacking Locations
-  Suspension Contact Hoist Locations

G99D03397

Fig. 21: Lifting Points ("Y" Body)
 Courtesy of General Motors Corp.

WHEEL ALIGNMENT PROCEDURES

ORDER OF ALIGNMENT

NOTE: To ensure accurate alignment, align wheels in the following order: rear camber, rear toe-in, front caster, front camber and front toe-in.

CAMBER ADJUSTMENT (REAR)

"E" Body

Loosen front and rear inside control arm mounting bolts. See Fig. 22. Move lower control arm inward or outward as necessary to adjust camber. Tighten bolts to specification. See TORQUE SPECIFICATIONS.

"W" Body

1) Raise and support vehicle. Remove rear wheel. Remove strut. File the upper bolt hole at lower end of strut to make it oblong. See Fig. 23.

2) Install strut, but DO NOT fully tighten strut mounting bolts at steering knuckle. Lower vehicle. Adjust camber to specification. See WHEEL ALIGNMENT SPECIFICATIONS table. Tighten bolts to specification. See TORQUE SPECIFICATIONS.

"Y" Body

Loosen lower control arm cam bolt nut. Rotate cam bolt until camber is within specification. See Fig. 24. See WHEEL ALIGNMENT SPECIFICATIONS table. Tighten bolts to specification. See TORQUE SPECIFICATIONS.

Except "E", "W" & "Y" Bodies

Rear camber is not adjustable. If rear camber is not as specified, repair or replace worn or damaged suspension components.

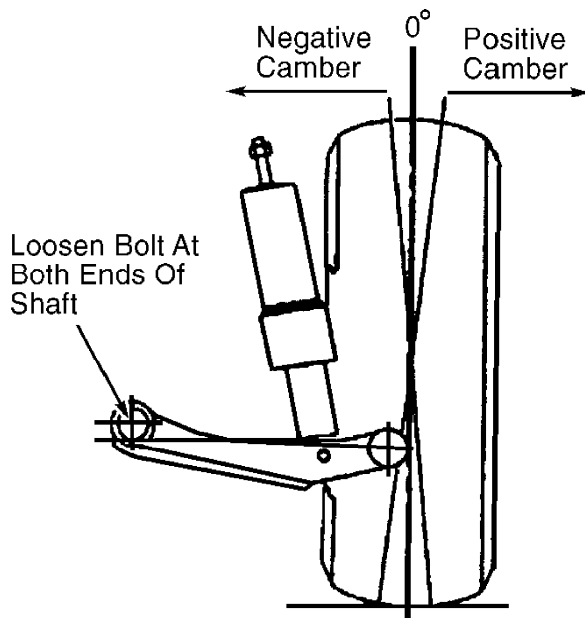

G95F14626

Fig. 22: Adjusting Rear Camber ("E" Body)
Courtesy of General Motors Corp.

Before Filing

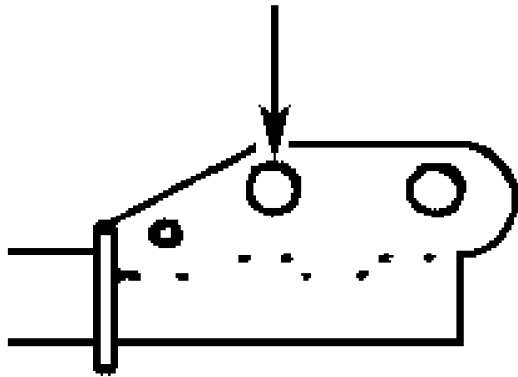

After Filing

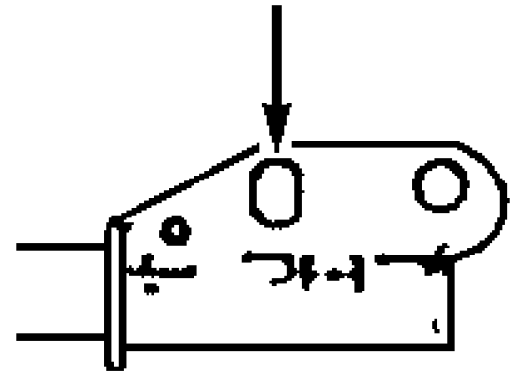

G97A03517

Fig. 23: Elongating Rear Strut Bolt Hole For Camber Adjustment ("W" Body)
Courtesy of General Motors Corp.

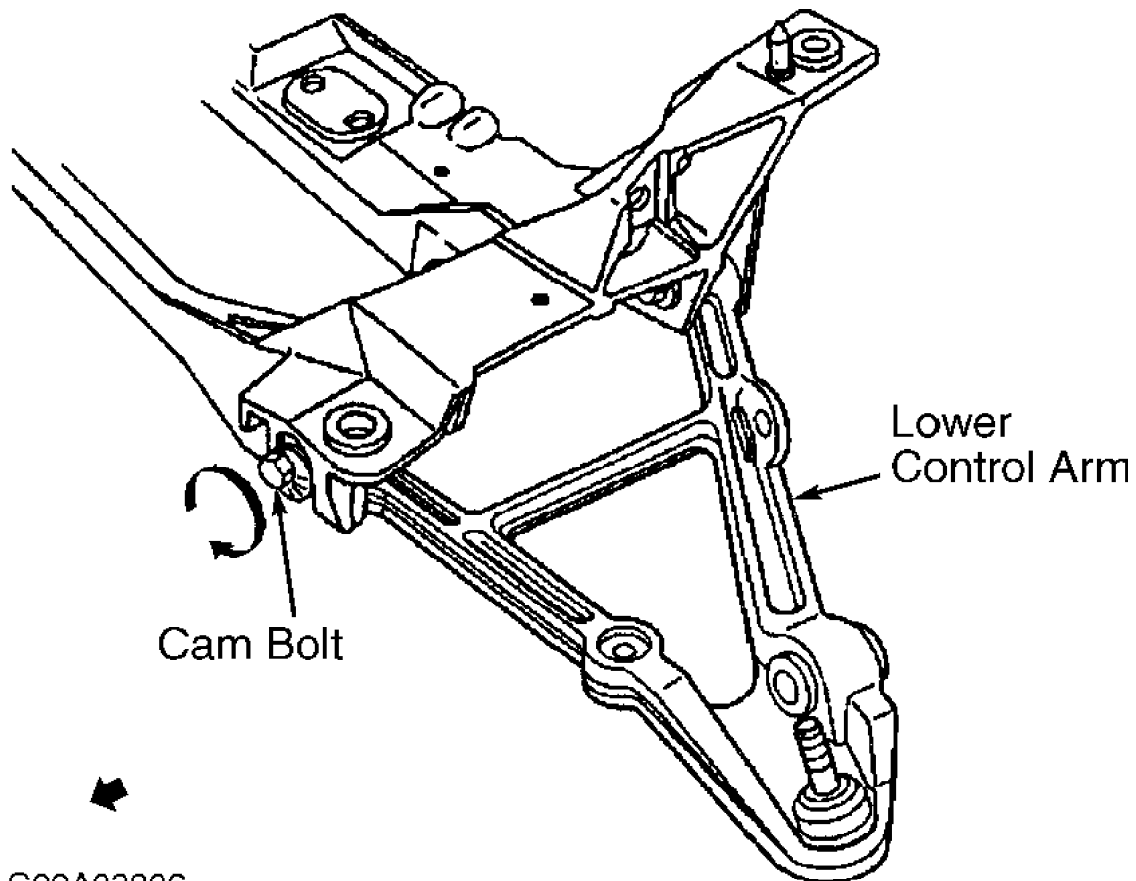

G99A03206

Fig. 24: Adjusting Rear Camber ("Y" Body)
Courtesy of General Motors Corp.

TOE-IN ADJUSTMENT (REAR)

"C", "G", "H" & "K" Bodies

Adjust left and right sides separately. Loosen inner adjustment link cam nut. See Fig. 25. Rotate cam bolt until toe-in is as specified. See WHEEL ALIGNMENT SPECIFICATIONS table. Tighten cam nut to specification. See TORQUE SPECIFICATIONS.

"E" Body

Loosen toe link bolt. See Fig. 26. Move wheel inward or outward as necessary until toe-in is as specified. See WHEEL ALIGNMENT SPECIFICATIONS table. Tighten bolts to specification. See TORQUE SPECIFICATIONS.

"M" Body

Loosen right and left body side control rod cam bolts. Rotate cam bolt until toe-in is as specified. See WHEEL ALIGNMENT SPECIFICATIONS table. Tighten lock nut to specification. See TORQUE SPECIFICATIONS.

"S" Body

Loosen both tie rod end lock nuts. Rotate threaded sleeve until toe-in as specified. See WHEEL ALIGNMENT SPECIFICATIONS table. Tighten lock nut to specification. See TORQUE SPECIFICATIONS.

"V" Body

Loosen rear tie rod adjuster clamps. Rotate threaded sleeve until rear toe-in is as specified. See WHEEL ALIGNMENT SPECIFICATIONS table. Tighten adjuster clamps to specification. See TORQUE SPECIFICATIONS.

"W" Body (Except Lumina)

Adjust left and right sides separately. Loosen nuts at rear wheel spindle rod. Adjust toe to proper setting. See WHEEL ALIGNMENT SPECIFICATIONS table. Tighten rear wheel spindle rod nuts to specification. See TORQUE SPECIFICATIONS.

"W" Body (Lumina)

1) Adjust left and right sides separately. Lubricate threads of Rear Toe Adjuster (J-38118). Install adjuster in rear rod access hole closest to center of rear suspension support and other end to rear suspension support. See Fig. 27. Hand-tighten adjuster in direction of adjustment.

2) Loosen nut on bolt securing rear suspension rod to crossmember at least 4 turns. Rotate adjuster as necessary until rear toe-in is as specified. See WHEEL ALIGNMENT SPECIFICATIONS table. Tighten rear suspension rod nut at crossmember to specification. See TORQUE SPECIFICATIONS.

"Y" Body

Loosen lock nut on rear tie rod. Rotate tie rod as necessary until rear toe-in is as specified. See WHEEL ALIGNMENT SPECIFICATIONS table. Tighten lock nut to specification. See Fig. 28. See TORQUE SPECIFICATIONS.

All Others

Rear toe-in is not adjustable. If rear toe-in is not as specified, repair or replace worn or damaged suspension components.

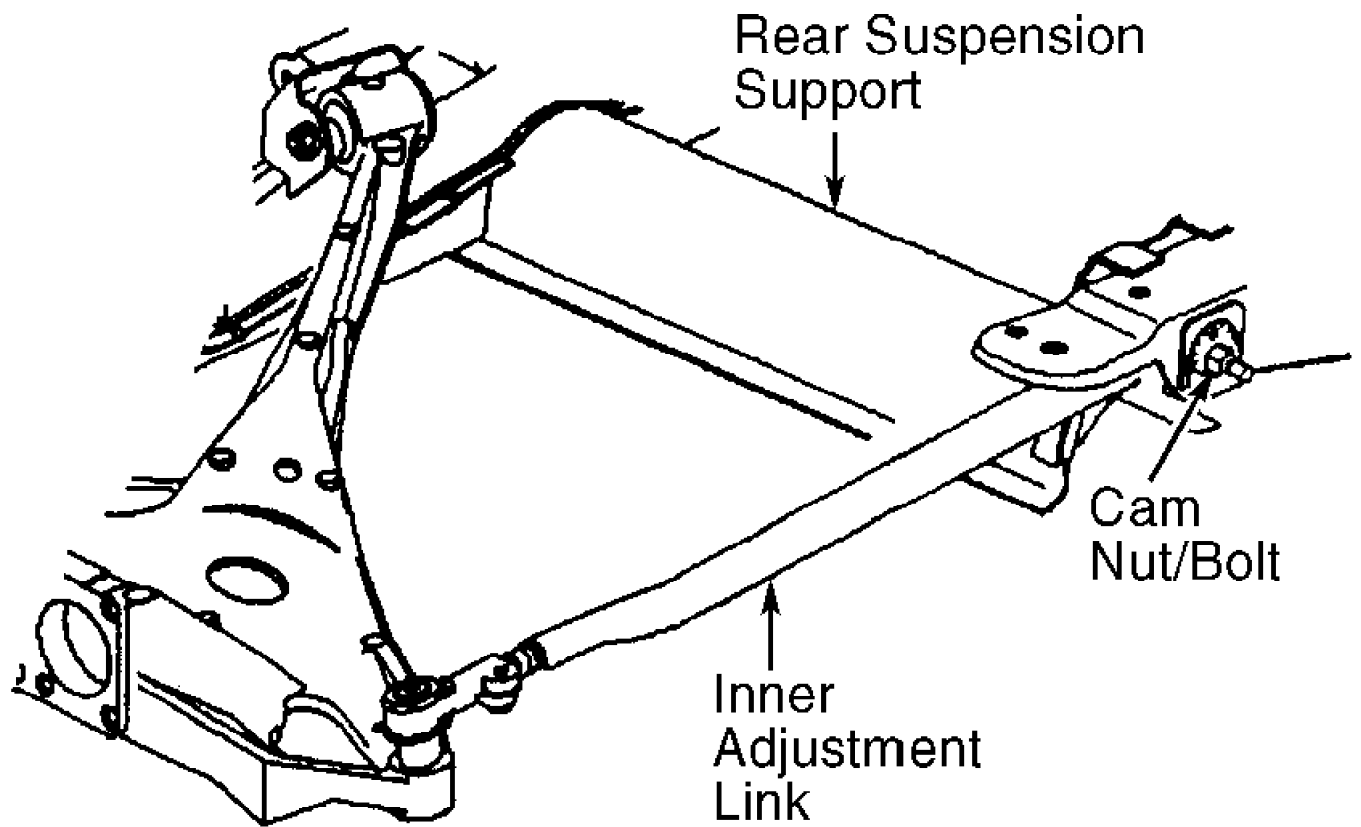

G95B14630

Fig. 25: Adjusting Rear Toe-In ("C", "G", "H" & "K" Bodies)
 Courtesy of General Motors Corp.

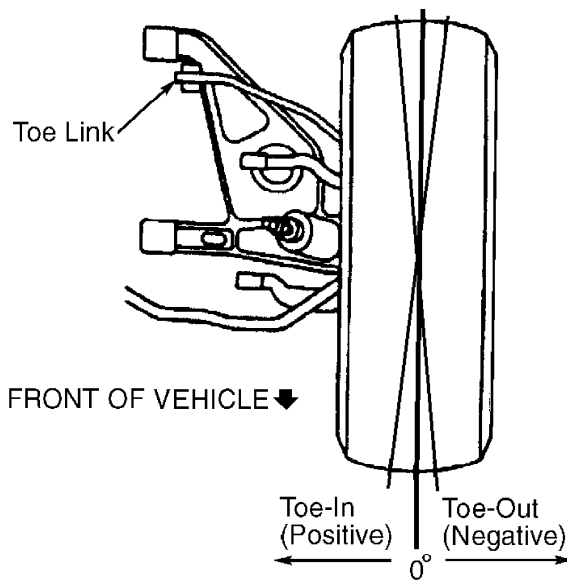

G95I14629

Fig. 26: Adjusting Rear Toe-In ("E" Body)
 Courtesy of General Motors Corp.

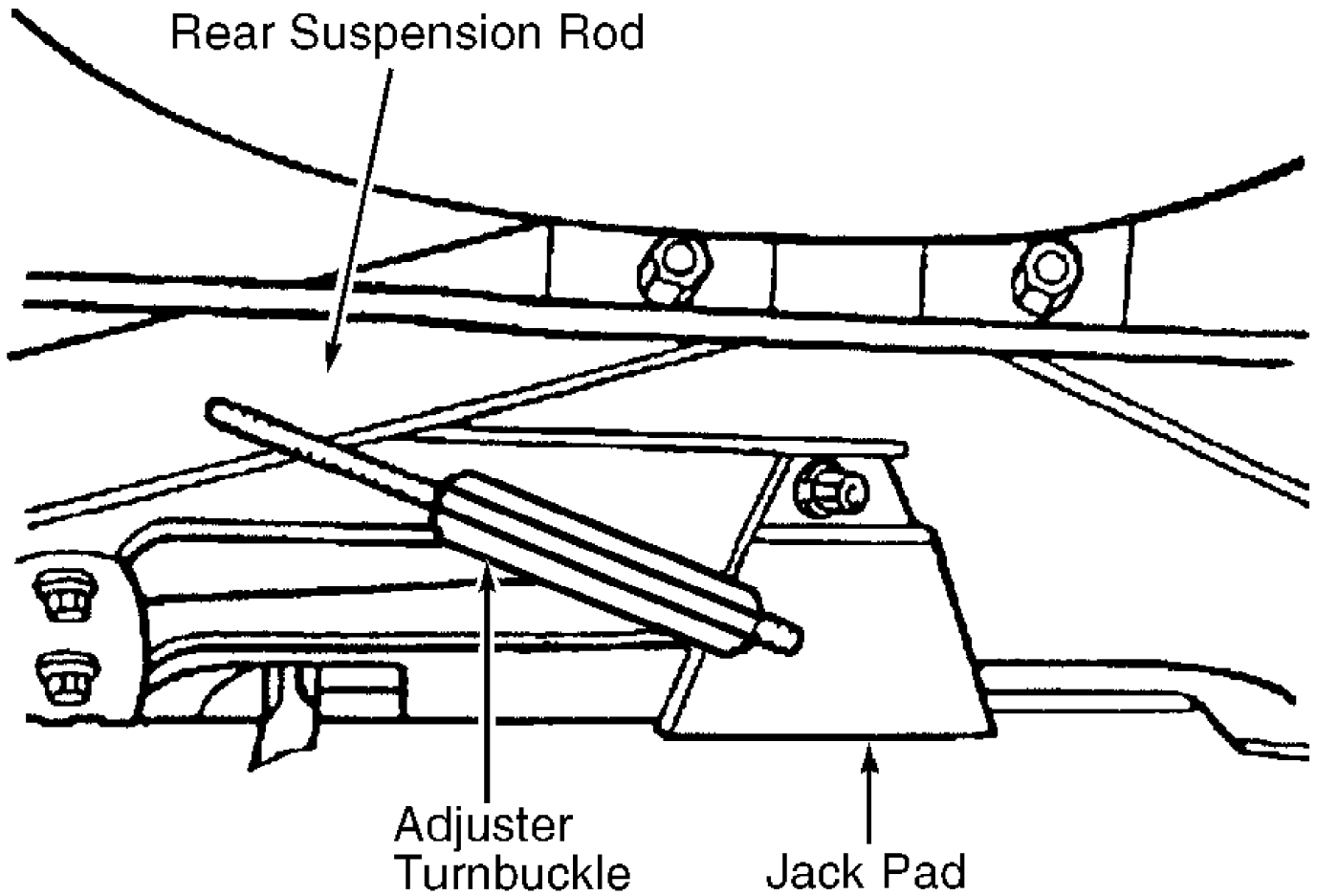

G95C14631

Fig. 27: Adjusting Rear Toe-In ("W" Body - Lumina)
 Courtesy of General Motors Corp.

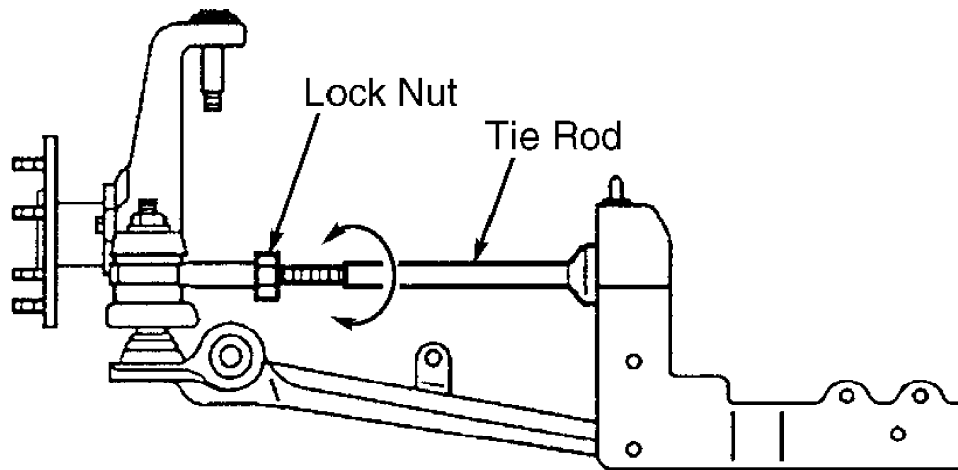

G99C03207

Fig. 28: Adjusting Rear Toe-In ("Y" Body)
 Courtesy of General Motors Corp.

CASTER ADJUSTMENT

"C", "G", "H" & "K" Bodies

1) With vehicle on ground (suspension loaded), remove nuts securing strut upper mount to body at each strut tower. See Fig. 29. Raise front of vehicle until strut studs have cleared holes.

2) Remove guide pins. Elongate each strut stud hole, then file excess material between holes. Lower vehicle to install strut into tower. Adjust caster to specification by moving top of strut forward or rearward. See WHEEL ALIGNMENT SPECIFICATIONS table. Tighten nuts to specification. See TORQUE SPECIFICATIONS.

"E" Body

Support vehicle by its wheels (suspension loaded). Remove nuts and washers from front strut mounting tower. See Fig. 29. Move top of strut forward and/or rearward as necessary to adjust caster. See WHEEL ALIGNMENT SPECIFICATIONS table. Tighten nuts to specification. See TORQUE SPECIFICATIONS table.

"F" Body

Loosen nuts on bolts securing lower control arm to crossmember. Attach Caster/Camber Adjuster (J-38658) to crossmember and lower control arm. See Fig. 30. Rotate adjuster clockwise to increase caster or counterclockwise to decrease caster. Adjust caster to specification. See WHEEL ALIGNMENT SPECIFICATIONS table. Tighten nuts to specification. See TORQUE SPECIFICATIONS table. Remove adjuster.

"J", "M", "N", "S", "V" & "W" Bodies

Caster is not adjustable. If caster is not as specified, check for worn or damaged suspension or body parts. Repair or replace as necessary.

Loosen These Nuts

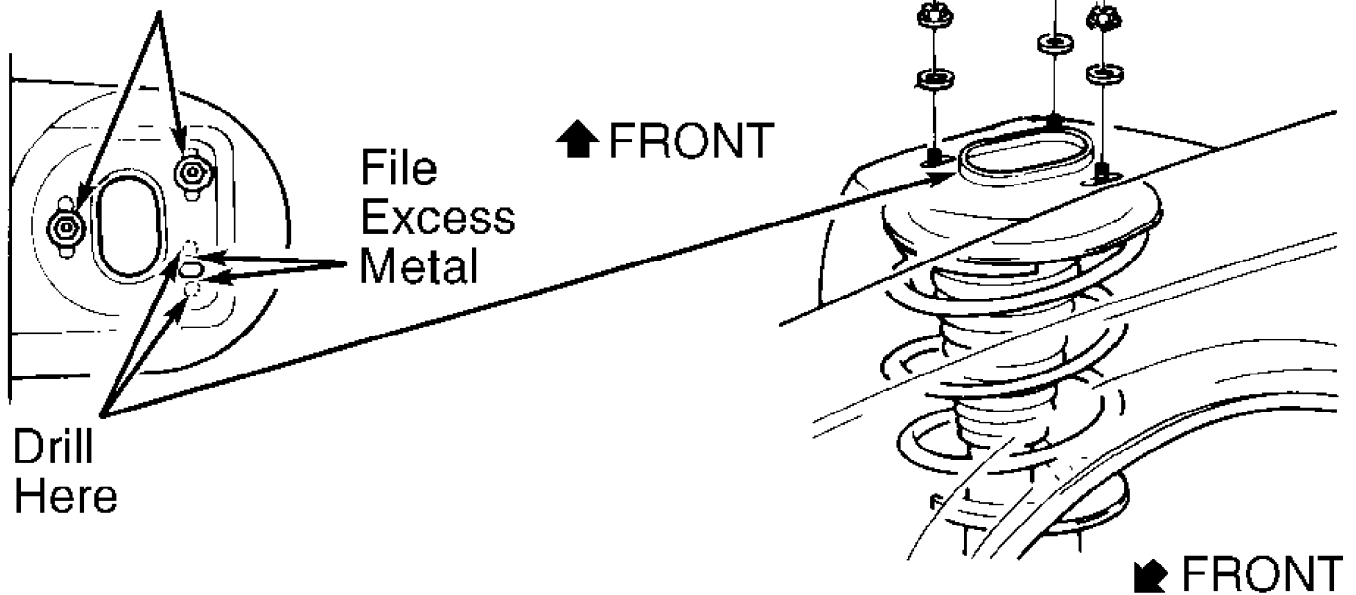

G95D14632

Fig. 29: Adjusting Caster ("C", "E", "G", "H" & "K" Bodies)
Courtesy of General Motors Corp.

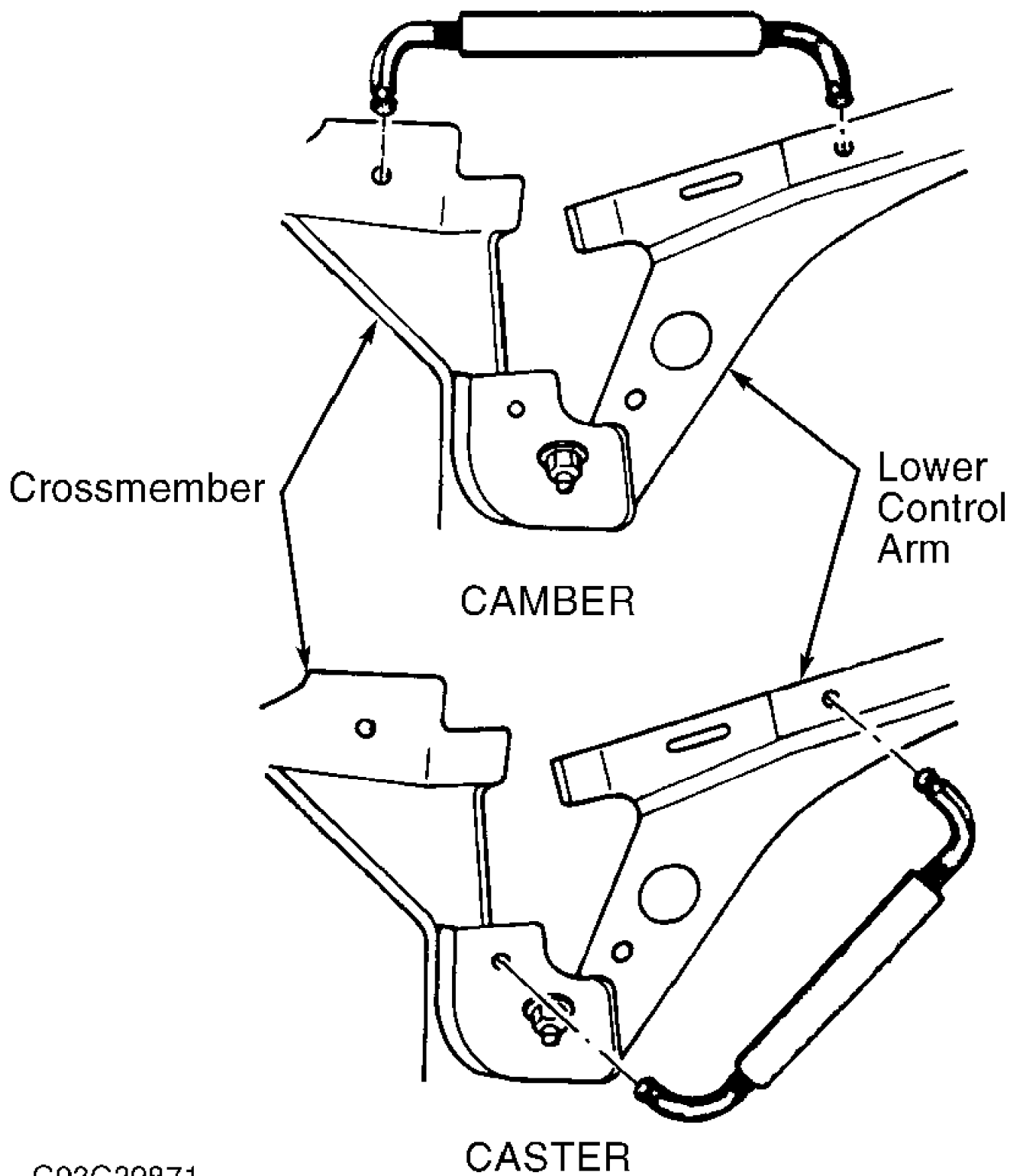

G93G39871

Fig. 30: Adjusting Front Camber & Caster ("F" Body)
Courtesy of General Motors Corp.

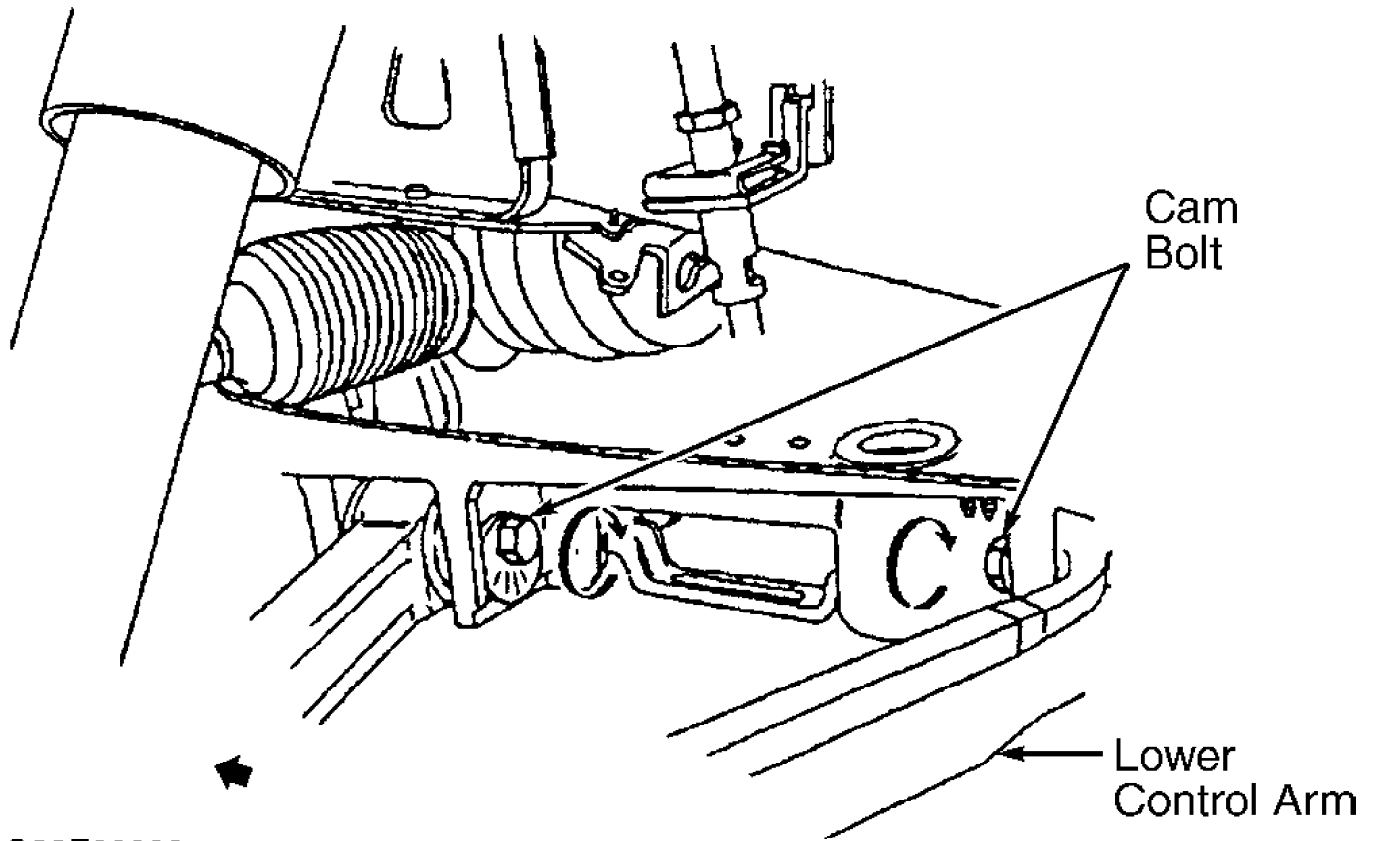

G99E03208

Fig. 31: Adjusting Front Camber & Caster ("Y" Body)
 Courtesy of General Motors Corp.

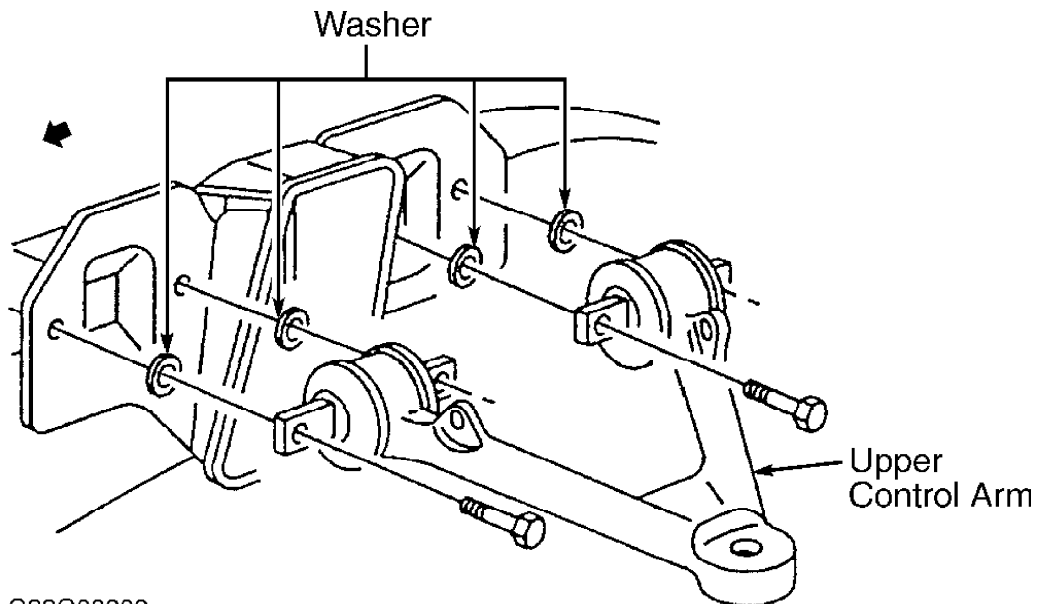

G99G03209

Fig. 32: Removing/Adding Upper Control Arm Washers ("Y" Body)
 Courtesy of General Motors Corp.

"Y" Body

Loosen lower control arm cam bolt nuts. Rotate cam bolts to

required camber specification. See Fig. 31. See WHEEL ALIGNMENT SPECIFICATIONS table. Tighten nuts to specification. See TORQUE SPECIFICATIONS. If unable to achieve specification for caster, washers at upper control arm can be added or subtracted to obtain specification. See Fig. 32.

CAMBER ADJUSTMENT (FRONT)

"C", "G", "H" & "K" Bodies

Loosen nuts on 2 bolts securing strut to steering knuckle. See Fig. 33. Install Camber Adjuster (J-39601). Rotate bolt on camber adjuster until camber is as specified. See WHEEL ALIGNMENT SPECIFICATIONS table. Tighten nuts to specification. See TORQUE SPECIFICATIONS.

"E" Body

Loosen nuts on bolts securing strut to steering knuckle. See Fig. 33. Tighten or loosen camber adjusting bolt as necessary to adjust camber to specification. See WHEEL ALIGNMENT SPECIFICATIONS table. While holding wheel in position, tighten nuts to specification. See TORQUE SPECIFICATIONS.

"F" Body

Loosen nuts on bolts securing lower control arm to crossmember. Attach Adjuster (J-38658) to crossmember and lower control arm. See Fig. 30. Rotate turnbuckle clockwise to increase camber or counterclockwise to decrease camber. Adjust camber to specification. See WHEEL ALIGNMENT SPECIFICATIONS table. Tighten nuts to specification. See TORQUE SPECIFICATIONS. Remove adjuster.

"J" & "N" Bodies

1) Remove nuts and bolts securing strut to steering knuckle. See Fig. 34. If lower bolt hole has been elongated, go to step 3). See Fig. 35. If lower bolt hole has NOT been elongated, go to next step.
2) Disengage strut from steering knuckle. Reposition strut at lower control arm. Elongate lower bolt hole. Paint exposed metal with rust-preventive paint or primer.
3) Install bolts and nuts, but DO NOT tighten nuts. Move top of wheel inward or outward as necessary until camber is as specified. See WHEEL ALIGNMENT SPECIFICATIONS table. Tighten nuts to specification. See TORQUE SPECIFICATIONS.

"V" Body

Remove brake caliper, and wire aside. DO NOT disconnect hydraulic line. Remove strut to steering knuckle bolts. Replace with NEW bolts and tighten to 15 ft. lbs. (20 N.m). Clean brake caliper mounting bolt threads to remove any residual locking compound. Apply 272 Threadlock or equivalent to NEW caliper mounting bolts. Install and tighten to specification. Reposition strut to adjust camber to specified range. See WHEEL ALIGNMENT SPECIFICATIONS table. Tighten bolts to specification. See TORQUE SPECIFICATIONS.

"W" Body (Except Lumina)

1) Raise and support vehicle. Remove rear wheel. Remove strut. File lower end of strut bolt hole to make lower bolt hole oblong. See Fig. 35.
2) Install strut, but DO NOT fully tighten strut mounting bolts at steering knuckle. Lower vehicle. Adjust camber to specification. See WHEEL ALIGNMENT SPECIFICATIONS table. Tighten bolts to specification. See TORQUE SPECIFICATIONS.

"W" Body (Lumina)

CAUTION: DO NOT lift vehicle by suspension parts. DO NOT overextend drive axles.

1) Loosen 3 strut cover attaching nuts. Remove strut cover. Lift front of vehicle enough to allow strut attaching studs to clear mounting holes. Cover top of strut to keep metal shavings from damaging strut. Using Template (J-36892) as a guide, file the 3 holes as necessary to allow for camber adjustment. See Fig. 36.

2) Paint exposed surfaces with rust-preventive paint or primer. Lower front of vehicle while aligning studs into holes. Install, but DO NOT tighten, 3 strut cover attaching nuts. Set camber to specification. Tighten strut cover attaching nuts to specification. See TORQUE SPECIFICATIONS.

"Y" Body

1) Loosen lower control arm cam bolt nuts. Rotate cam bolts to required camber specification. See Fig. 31. See WHEEL ALIGNMENT SPECIFICATIONS table. Tighten nuts to specification. See TORQUE SPECIFICATIONS.

2) If unable to set camber to specification using cam bolts, upper control arm shims can be added or subtracted. See Fig. 32. Ensure shims are of equal thickness to avoid caster change. If shims are removed to obtain additional negative camber, ensure there is proper clearance between upper control arm and shock absorber with suspension in full rebound.

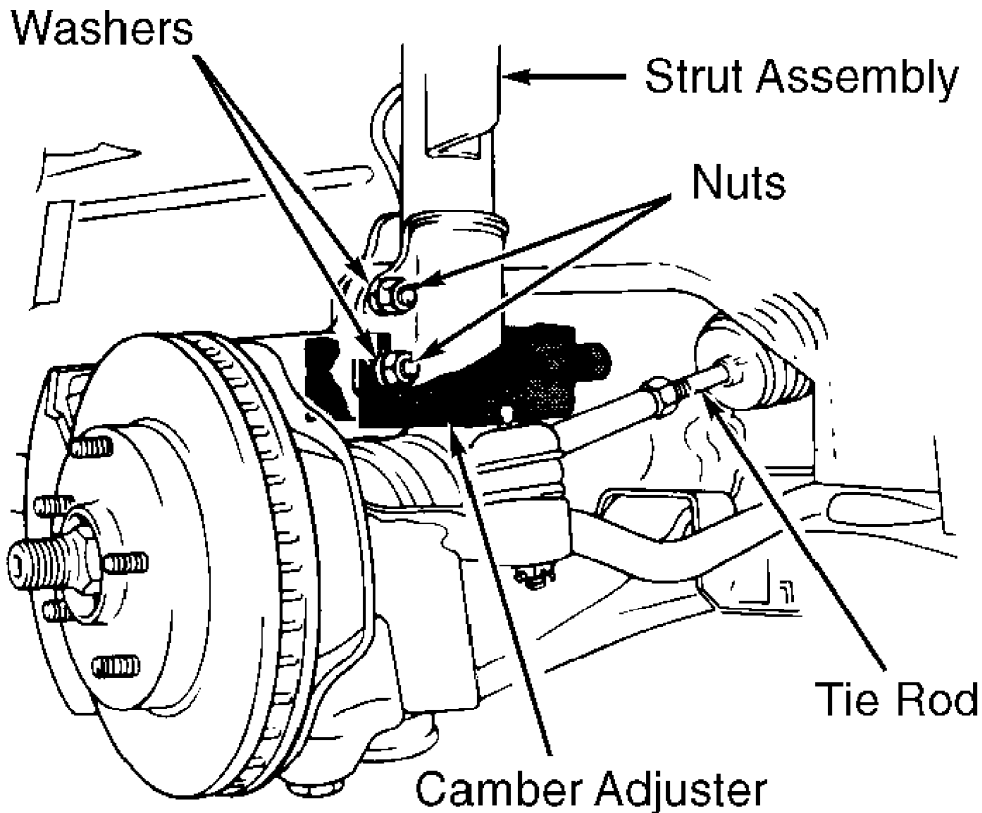

G95G14635

Fig. 33: Adjusting Front Camber ("C", "E", "G", "H" & "K" Bodies)
Courtesy of General Motors Corp.

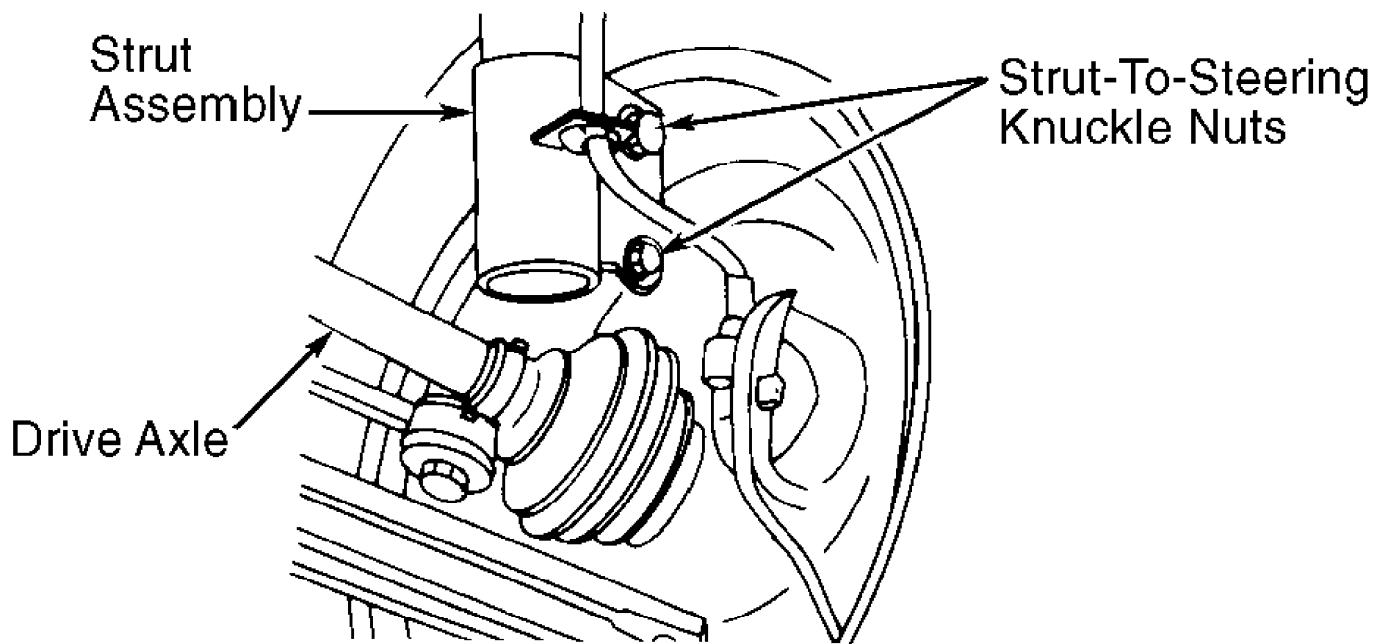

G95E14633

Fig. 34: Adjusting Front Camber ("J" & "N" Bodies)
 Courtesy of General Motors Corp.

Before Filing

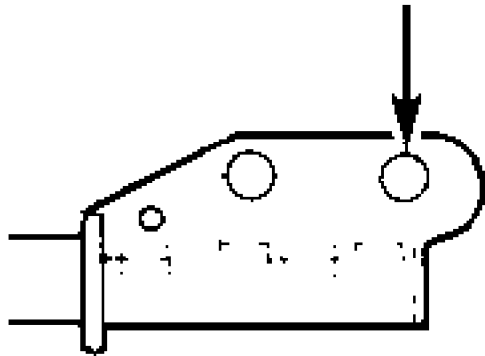

After Filing

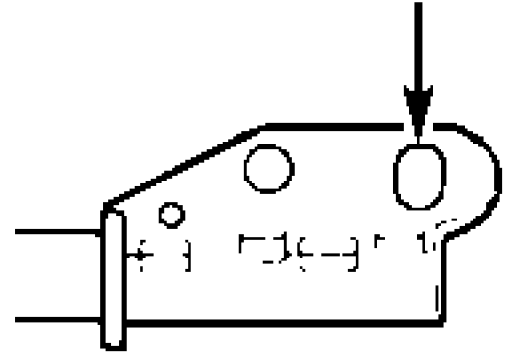

G95G14627

Fig. 35: Elongating Front Strut Bolt Hole For Camber Adjustment
 "W" Body - Except Lumina)
 Courtesy of General Motors Corp.

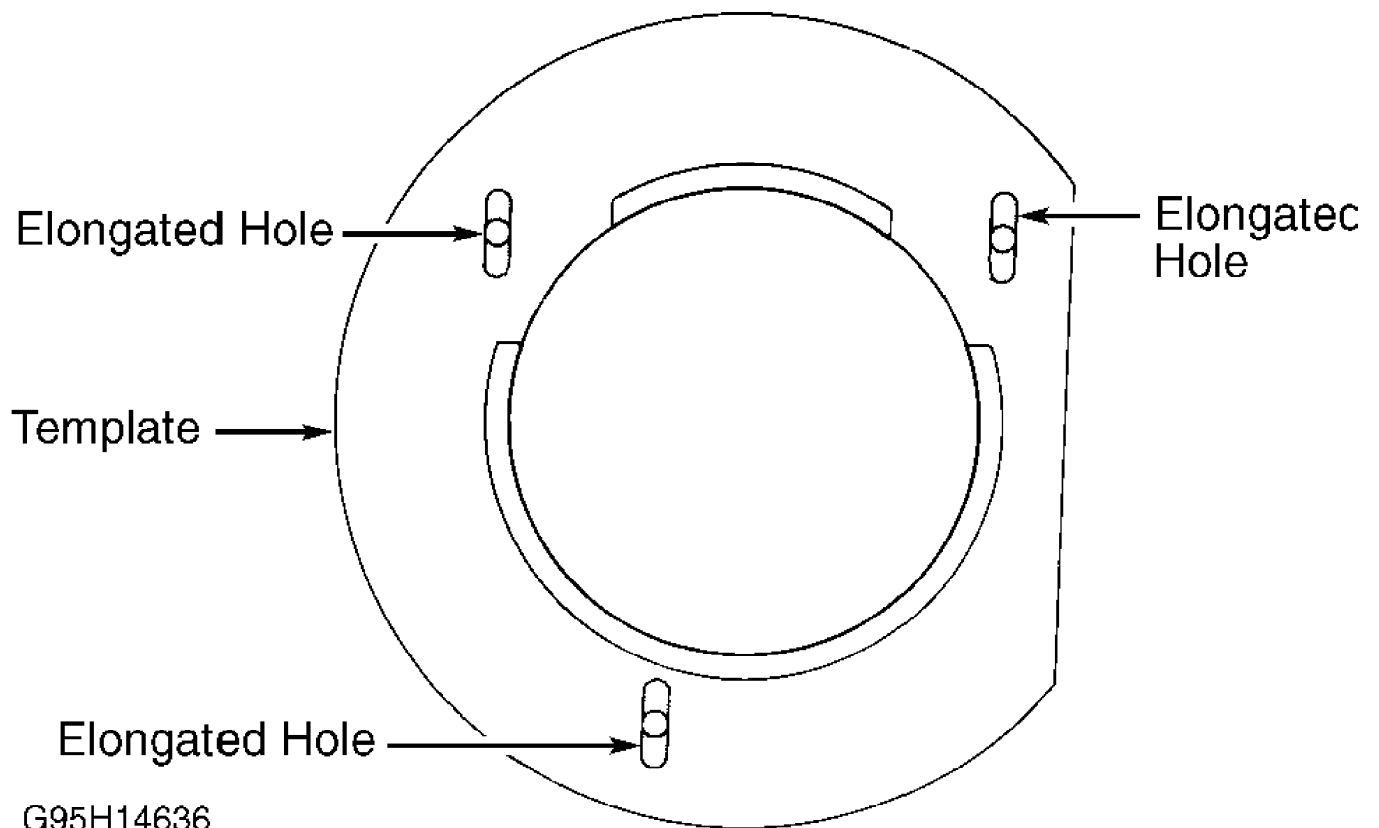

G95H14636

Fig. 36: Adjusting Front Camber ("W" Body - Lumina)
 Courtesy of General Motors Corp.

TOE-IN ADJUSTMENT (FRONT)

All Models

Loosen tie rod adjuster clamps, lock nut or jam nut. Rotate threaded sleeve or inner tie rod until required toe is obtained. See WHEEL ALIGNMENT SPECIFICATIONS table. Tighten adjuster clamps, lock nut or jam nut to specification. See TORQUE SPECIFICATIONS.

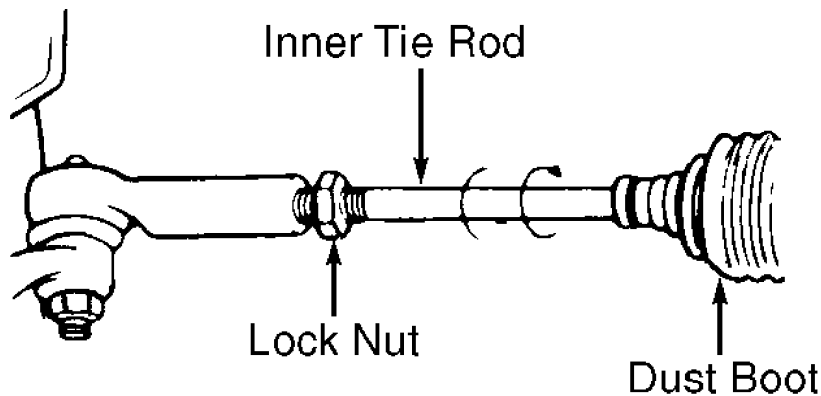

G95I14637

Fig. 37: Adjusting Front Toe-in
 Courtesy of General Motors Corp.

TORQUE SPECIFICATIONS

TORQUE SPECIFICATIONS

| Application | Ft. Lbs. (N.m) |
|---|----------------|
| "C" Body | |
| Adjustment Link Cam Nut | 55 (75) |
| Strut-To-Steering Knuckle Nut | 166 (225) |
| Strut-To-Strut Body Nut | 35 (47) |
| Tie Rod End Lock Nut | 47 (64) |
| "E" Body | |
| Rear Toe Link Bolt | 66 (90) |
| Strut-To-Steering Knuckle Nut | 136 (184) |
| Strut-To-Strut Tower Nut | 18 (24) |
| Tie Rod End Lock Nut | 46 (63) |
| "K" Body (DeVille) | |
| Adjustment Link Cam Nut | 55 (75) |
| Strut-To-Steering Knuckle Nut | 108 (147) |
| Strut-To-Tower Bolt | 30 (40) |
| Tie Rod End Lock Nut | 44 (60) |
| "K" Body (Seville) | |
| Adjusting Link Cam Bolt | 55 (75) |
| Strut-To-Steering Knuckle Nut | 129 (175) |
| Strut-To-Strut Tower Bolt | 30 (40) |
| Tie Rod End Lock Nut | 44 (60) |
| "F" Body | |
| Lower Control Arm-To-Crossmember Bolt | 96 (130) |
| Lower Control Arm-To-Crossmember Nut | 66 (90) |
| Tie Rod End Lock Nut | 35 (47) |
| "G" Body | |
| Adjustment Link Cam Nut | 55 (75) |
| Strut-To-Body Nut | 35 (47) |
| Strut-To-Steering Knuckle Nut | 136 (185) |
| Tie Rod End Lock Nut | 47 (64) |
| "H" Body | |
| Adjustment Cam Link Nut | 55 (75) |
| Strut-To-Steering Knuckle Nut | 136 (185) |
| Strut-To-Body Bolt | 35 (47) |
| Tie Rod End Lock Nut | 47 (64) |
| "J" Body | |
| Strut-To-Body Nut | 18 (24) |
| Strut-To-Steering Knuckle Nut | 133 (180) |
| Tie Rod End Lock Nut | 50 (68) |
| "M" Body | |
| Rear Cam Bolt Nut | 59 (80) |
| Tie Rod End Lock Nut | 33 (45) |
| "N" Body | |
| Strut-To-Steering Knuckle Nut | 133 (180) |
| Tie Rod End Lock Nut | 50 (68) |
| "S" Body | |
| Lower Strut Bolt (Front) | 203 (274) |
| Tie Rod End Lock Nut | 41 (56) |
| "V" Body | |
| Brake Caliper Mounting Bolts | (1) 70 (95) |
| Strut-To-Steering Knuckle Bolts | (2) 66 (90) |
| Tie Rod Adjuster Clamp Bolts | 11 (15) |
| "W" Body | |
| Century, Grand Prix & Regal | |
| Rear Wheel Spindle Rod | 37 (50) |
| Strut-To-Steering Knuckle Bolt | 90 (122) |
| Tie Rod End Lock Nut | 50 (68) |
| Intrigue, Lumina & Monte Carlo | |
| Spindle Rod Jam Nut (Rear) | 50 (68) |

| | |
|--|-----------|
| Strut-To-Steering Knuckle Bolt (Front) | 90 (122) |
| Strut-To-Steering Knuckle Bolt (Rear) | 82 (112) |
| Tie Rod End Jam Nut | 50 (68) |
| "Y" Body | |
| Adjustment Link Cam Nut | 55 (75) |
| Front Upper Control Arm Bolts | 42 (57) |
| Strut-To-Body Mounting Nut | 35 (47) |
| Strut-To-Steering Knuckle Nut | 136 (185) |
| Tie Rod End Lock Nut | 47 (64) |

(1) - Tighten an additional 37 degrees.
(2) - Tighten an additional 53 degrees.

WHEEL ALIGNMENT SPECIFICATIONS

WHEEL ALIGNMENT SPECIFICATIONS

| Application | Preferred | Range |
|-----------------------------|-----------|-------------------------------|
| "C" Body | | |
| Camber (1) | | |
| Front | - 0.2 | - 0.7 To 0.3 |
| Rear | - 0.3 | - 0.8 To 0.2 |
| Caster (1) | 6 | 5.5 To 6.5 |
| Toe-In (1) | | |
| Front | 0.2 | - 0.1 To 0.5 |
| Rear | 0.2 | 0 To 0.4 |
| Toe-In (2) | | |
| Front | 0.1 (2.5) | - 0.05 To 0.25 (- 1.3 To 6.4) |
| Rear | 0.1 (2.5) | 0 To 0.2 (0 To 5.1) |
| "E" & "K" Bodies | | |
| Eldorado | | |
| Camber (1) | | |
| Front | 0 | - 0.5 To 0.5 |
| Rear | 0 | - 0.5 To 0.5 |
| Caster (1) | 2.3 | 1.3 To 3.3 |
| Toe-In (1) | | |
| Front | 0.2 | 0 To 0.4 |
| Rear | 0.2 | 0 To 0.4 |
| Toe-In (2) | | |
| Front | 0.1 (2.5) | 0 To 0.2 (0 To 5.0) |
| Rear | 0.1 (2.5) | 0 To 0.2 (0 To 5.0) |
| Seville SLS/STS & DeVille | | |
| Camber (1) | | |
| DeVille & Seville SLS | | |
| Front | - 0.02 | - 0.07 To 0.3 |
| Rear | - 0.03 | - 0.08 To 0.2 |
| Seville STS | | |
| Front | - 0.2 | - 0.7 To 0.3 |
| Rear | - 0.6 | - 1.1 To - 0.1 |
| Caster (1) | 6 | 5.5 To 6.5 |
| Toe-In (1) | | |
| Front | 0.2 | 0 To 0.4 |
| Rear | 0.2 | 0 To 0.4 |
| Toe-In (2) | | |
| Front | 0.1 (2.5) | 0 To 0.2 (0 To 5) |
| Rear | 0.1 (2.5) | 0 To 0.2 (0 To 5) |
| "F" Body | | |
| Camber (1) | | |

| | | | | | | |
|------------|-------|------------|-----------|---------------|-------------------|---------|
| Front | | 0.4 | | - 0.1 | To 0.9 | |
| Rear | | 0 | | - 0.6 | To 0.6 | |
| Caster (1) | | 5.0 | | 4.5 | To 5.5 | |
| Toe-In (1) | | | | | | |
| Front | | 0 | | - 0.2 | To 0.2 | |
| Rear | | 0 | | - 0.3 | To 0.3 | |
| Toe-In (2) | | | | | | |
| Front | | 0 | ... - 0.1 | To 0.1 (- 2.5 | To 2.5) | |
| Rear | | 0 | ... - 0.2 | To 0.2 (- 4.0 | To 4.0) | |
| "G" Body | | | | | | |
| Camber (1) | | | | | | |
| Front | | - 0.2 | | - 0.7 | To 0.3 | |
| Rear | | - 0.3 | | - 0.8 | To 0.2 | |
| Caster (1) | | 6 | | 5.5 | To 6.5 | |
| Toe-In (1) | | | | | | |
| Front | | 0.2 | | 0 | To 0.4 | |
| Rear | | 0.2 | | 0 | To 0.4 | |
| Toe-In (2) | | | | | | |
| Front | | 0.1 (2.5) | | 0 | To 0.2 (0 To 5.0) | |
| Rear | | 0.1 (2.5) | | 0 | To 0.2 (0 To 5.0) | |
| "H" Body | | | | | | |
| Camber (1) | | | | | | |
| Front | | 0.2 | | - 0.3 | To 0.7 | |
| Rear | | - 0.8 | | - 0.8 | To 0.2 | |
| Caster (1) | | 6.0 | | 5.5 | To 6.5 | |
| Toe-In (1) | | | | | | |
| Front | | 0.2 | | 0 | To 0.4 | |
| Rear | | 0.2 | | 0 | To 0.4 | |
| Toe-In (2) | | | | | | |
| Front | | 0.1 (2.5) | | 0 | To 0.2 (0 To 5.0) | |
| Rear | | 0.1 (2.5) | | 0 | To 0.2 (0 To 5.0) | |
| "J" Body | | | | | | |
| Camber (1) | | | | | | |
| Front | | - 0.2 | | - 1.2 | To 0.8 | |
| Rear | | - 0.3 | | - 1.0 | To 0.5 | |
| Caster (1) | | 4.3 | | 3.3 | To 5.3 | |
| Toe-In (1) | | | | | | |
| Front | | 0.1 | | - 0.15 | To 0.35 | |
| Rear | | 0.2 | | - 0.1 | To 0.5 | |
| Toe-In (2) | | | | | | |
| Front | | 0.05 (1.5) | | - 0.07 | To 0.17 (- 1.5 | To 4) |
| Rear | | 0.1 (2.5) | | - 0.05 | To 0.25 (- 1.5 | To 6.5) |
| "M" Body | | | | | | |
| Camber (1) | | | | | | |
| Front | | 0 | | - 0.5 | To 0.5 | |
| Rear | | 0 | | - 0.5 | To 0.5 | |
| Caster (1) | | 3 | | 2 | To 4 | |
| Toe-In (1) | | | | | | |
| Front | | 0.16 | | 0 | To 0.3 | |
| Rear | | 0.45 | | 0.3 | To 0.6 | |
| Toe-In (2) | | | | | | |
| Front | | 0.08 (2) | | 0 | To 0.16 (0 To 4) | |
| Rear | | 0.23 (6) | | 0.15 | To 0.3 (4 To 7.5) | |
| "N" Body | | | | | | |
| Camber (1) | | | | | | |
| Front | | - 0.2 | | - 1.2 | To 0.8 | |
| Rear | | - 0.2 | | - 0.7 | To 0.30 | |
| Caster (1) | | 4.1 | | 3.1 | To 5.1 | |
| Toe-In (1) | | | | | | |
| Front | | 0.1 | | - 0.15 | To 0.35 | |
| Rear | | 0.06 | | - 0.26 | To 0.14 | |

| | | | | | |
|-----------------------------|------------|--|------------------|----------------|--|
| Toe-In (2) | | | | | |
| Front | 0.05 (1.5) | | - 0.07 To 0.17 | (- 1.5 To 4.0) | |
| Rear | 0.03 (1.0) | | - 0.13 To 0.07 | (- 2.5 To 2.5) | |
| "S" Body | | | | | |
| Camber (1) | | | | | |
| Front | - 0.18 | | - 0.93 To 0.57 | | |
| Rear | - 0.92 | | - 1.67 To - 0.17 | | |
| Caster (1) | 1.33 | | 0.58 To 2.08 | | |
| Toe-In (1) | | | | | |
| Front | 0.1 | | - 0.1 To 0.3 | | |
| Rear | 0.4 | | 0.2 To 0.6 | | |
| Toe-In (2) | | | | | |
| Front | 0.05 (1.5) | | - 0.05 To 0.15 | (- 1.5 To 4) | |
| Rear | 0.25 (5.0) | | 0.1 To 0.3 | (2.5 To 7.5) | |
| "V" Body | | | | | |
| Camber (1) | | | | | |
| Front | 0.5 | | 1.15 To 1.35 | | |
| Rear | 1.8 | | 2.45 To 1.08 | | |
| Caster (1) | 5.0 | | 3.9 To 4.9 | | |
| Toe-In (1) | | | | | |
| Front | 0.3 | | 0.09 To 0.41 | | |
| Rear | 0.1 | | 0.10 To 0.22 | | |
| Toe-In (2) | | | | | |
| Front | 0.12 (3.0) | | 0.04 To 0.20 | (1.0 To 5.0) | |
| Rear | 0.03 (1.0) | | 0.05 To 0.11 | (- 1.5 To 3.0) | |
| "W" Body | | | | | |
| Century, Grand Prix & Regal | | | | | |
| With 15" Wheels | | | | | |
| Camber (1) | | | | | |
| Front | - 0.9 | | - 1.35 To - 0.35 | | |
| Rear | - 0.9 | | - 1.4 To - 0.4 | | |
| Caster (1) | 3.2 | | 2.7 To 3.7 | | |
| Toe-In (1) | | | | | |
| Front | 0.1 | | - 0.1 To 0.3 | | |
| Rear | 0.1 | | - 0.1 To 0.3 | | |
| Toe-In (2) | | | | | |
| Front | 0.05 (1.5) | | - 0.05 To 0.15 | (- 1.5 To 4) | |
| Rear | 0.05 (1.5) | | - 0.05 To 0.15 | (- 1.5 To 4) | |
| With 16" Wheels | | | | | |
| Camber (1) | | | | | |
| Front | - 0.94 | | - 1.44 To - 0.44 | | |
| Rear | - 0.1 | | - 1.5 To - 0.5 | | |
| Caster (1) | 3.2 | | 2.7 To 3.7 | | |
| Toe-In (1) | | | | | |
| Front | 0.1 | | - 0.1 To 0.3 | | |
| Rear | 0.1 | | - 0.1 To 0.3 | | |
| Toe-In (2) | | | | | |
| Front | 0.05 (1.5) | | - 0.05 To 0.15 | (- 1.5 To 4) | |
| Rear | .05 (1.5) | | - 0.05 To 0.15 | (- 1.5 To 4) | |
| Impala & Monte Carlo (2000) | | | | | |
| With 15" Wheels | | | | | |
| Camber (1) | | | | | |
| Front | 0.9 | | - 0.35 To - 1.35 | | |

| | | | | | |
|------------|-------|-----------|-------|--------|--------------------------|
| Rear | | - 0.9 | | - 0.40 | To 1.40 |
| Caster (1) | | 3.2 | | 2.7 | To 3.7 |
| Toe-In (1) | | | | | |
| Front | | 0.1 | | 0.1 | To 0.3 |
| Rear | | 0.1 | | - 0.1 | To 0.3 |
| Toe-In (2) | | | | | |
| Front | | 0.1 (1.5) | | - 0.1 | To 0.2 (- 1.5 To 4.0) |
| Rear | | 0.1 (1.5) | | - 0.1 | To 0.2 (- 1.5 To 4.0) |

With 16" Wheels

| | | | | | |
|------------|-------|-----------|-------|--------|---------------------------|
| Camber (1) | | | | | |
| Front | | 0.9 | | 1.44 | To 0.44 |
| Rear | | - 1.0 | | 1.50 | To - 0.50 |
| Caster (1) | | 3.2 | | 2.7 | To 3.7 |
| Toe-In (1) | | | | | |
| Front | | 0.1 | | - 0.1 | To 0.3 |
| Rear | | 0.1 | | -0.1 | To 0.3 |
| Toe-In (2) | | | | | |
| Front | | 0.1 (1.5) | | - 0.05 | To 0.15 (- 1.5 To 4.0) |
| Rear | | 0.1 (1.5) | | - 0.05 | To 0.15 (- 1.5 To 4.0) |

Impala (2001)

| | | | | | |
|------------|-------|------------|-------|--------|-------------------------|
| Camber (1) | | | | | |
| Front | | - 0.9 | | - 0.40 | To - 1.40 |
| Rear | | 0 | | - 0.50 | To 0.50 |
| Caster (1) | | 0 | | 2.70 | To 3.70 |
| Toe-In (1) | | | | | |
| Front | | 0.1 | | - 0.1 | To 0.3 |
| Rear | | 0.1 | | - 0.1 | To 0.3 |
| Toe-In (2) | | | | | |
| Front | | 0.05 (1.5) | | - 0.05 | To 0.15 (- 1.5 To 4) |
| Rear | | 0.05 (1.5) | | - 0.05 | To 0.15 (- 1.5 To 4) |

Intrigue

| | | | | | |
|-------------|-------|------------|-------|--------|-------------------------|
| Camber (1) | | | | | |
| Front | | - 0.9 | | - 1.40 | To - 0.40 |
| Rear (2000) | | - 0.5 | | - 1.02 | To - 0.02 |
| Rear (2001) | | - 0.9 | | - 1.40 | To - 0.40 |
| Caster (1) | | 3.05 | | 2.55 | To 3.55 |
| Toe-In (1) | | | | | |
| Front | | 0.1 | | - 0.1 | To 0.3 |
| Rear | | 0.1 | | - 0.15 | To 0.25 |
| Toe-In (2) | | | | | |
| Front | | 0.05 (1.5) | | - 0.05 | To 0.15 (- 1.5 To 4) |
| Rear | | 0.05 (1.5) | | - 0.07 | To 0.12 (- 1.5 To 3) |

Lumina

| | | | | | |
|------------|-------|--------|-------|--------|---------------------------|
| Camber (1) | | | | | |
| Front | | - 0.70 | | 0.20 | To 1.20 |
| Rear | | | | | |
| 15" Wheels | | - 0.35 | | - 0.85 | To 0.15 |
| 16" Wheels | | - 0.45 | | - 0.95 | To 0.05 |
| Caster (1) | | 1.8 | | 1.30 | To 2.30 |
| Toe-In (1) | | | | | |
| Front | | 0 | | - 0.2 | To 0.2 |
| Rear | | 0 | | - 0.3 | To 0.3 |
| Toe-In (2) | | | | | |
| Front | | 0 (0) | | - 0.10 | To 0.10 (- 2.5 To 2.5) |

Rear 0 (0) - 0.10 To 0.10 (- 2.5
To 2.5)

Monte Carlo (2001)

Camber (1)

Front - 0.70 - 0.50 To - 0.90

Rear 0 - 0.70 To 0.70

Caster (1) 0 2.70 To 3.70

Toe-In (1)

Front 0.1 - 0.1 To 0.3

Rear 0.1 - 0.1 To 0.3

Toe-In (2)

Front 0.05 (1.5) - 0.05 To 0.15 (- 1.5
To 4)

Rear 0.05 (1.5) - 0.05 To 0.15 (- 1.5
To 4)

"Y" Body

Camber (1)

Front - 0.2 - 0.7 To 0.3

Rear - 0.2 - 0.7 To 0.3

Caster (1) 6.1 5.6 To 6.6

Toe-In (1)

Front 0.08 - 0.12 To 0.28

Rear - 0.02 - 0.22 To 0.18

Toe-In (2)

Front 0.04 (1.0) .. - 0.06 To 0.14 (- 1.5 To 3.5)

Rear - 0.01 (0.5) ... - 0.11 To 0.09 (- 3 To 2)

(1) - Measurement is in degrees.

(2) - Measurement is in inches (mm).
