

# VACUUM DIAGRAMS

## 2001 Chevrolet Camaro

2001 ENGINE PERFORMANCE  
Vacuum Diagrams - Cars

### INTRODUCTION

This article contains underhood views or schematics of vacuum hose routing. Use these vacuum diagrams as a guide during the visual inspection in appropriate BASIC DIAGNOSTIC PROCEDURES article. This will assist in identifying improperly routed vacuum hoses which may cause driveability and/or computer-indicated malfunctions. Always verify vacuum hose routing using underhood emission and vacuum label (if equipped) for specific applications.

NOTE: If underhood vacuum label and diagram in manual differ, underhood label should always take precedent, unless it is suspected of not being correct application.

### EMISSION CONTROL DEVICE ABBREVIATIONS

ACSRY - Accessory.  
CNSTR - Canister.  
CSI - Central Sequential Port Injection.  
CVS - Canister Vent Solenoid.  
EGR - Exhaust Gas Recirculation.  
EGR SOL - EGR Solenoid.  
EVAP - Evaporative.  
HVAC - Heating, Ventilation & A/C System.  
LEV - Low Emissions Vehicle.  
MAP - Manifold Air Pressure Sensor.  
PCV - Positive Crankcase Ventilation.  
PV - Purge Valve.  
PRES - Pressure.  
REG - Regulator.  
SFI - Sequential Fuel Injection.  
SOL - Solenoid.  
TPCSV - Tank Pressure Control Solenoid Valve.  
TPCV - Tank Pressure Control Valve.  
VAC - Vacuum.  
VLV - Valve.

### VACUUM DIAGRAMS

NOTE: Vacuum diagrams for applications not shown were not available from manufacturer. Use underhood emission and vacuum labels.

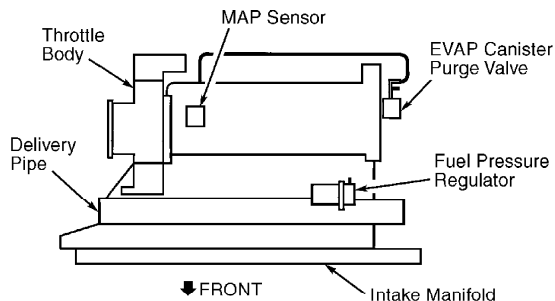

G98J00264  
Fig. 1: Vacuum Diagram - 1.3L SFI (VIN 2) Metro  
Courtesy of General Motors Corp.

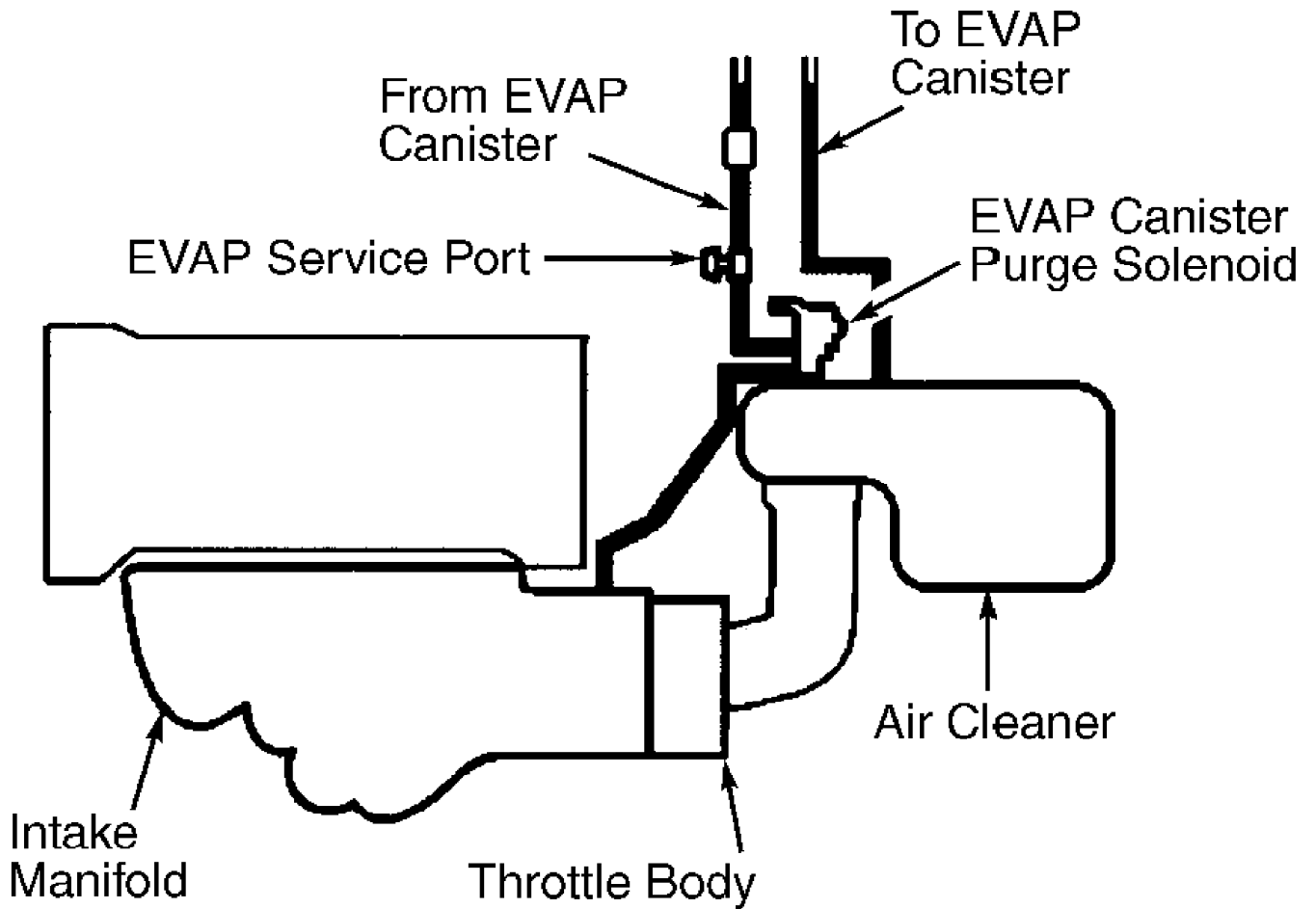

G00012672

Fig. 2: Vacuum Diagram - 1.8L SFI (VIN 8) Prizm  
 Courtesy of General Motors Corp.

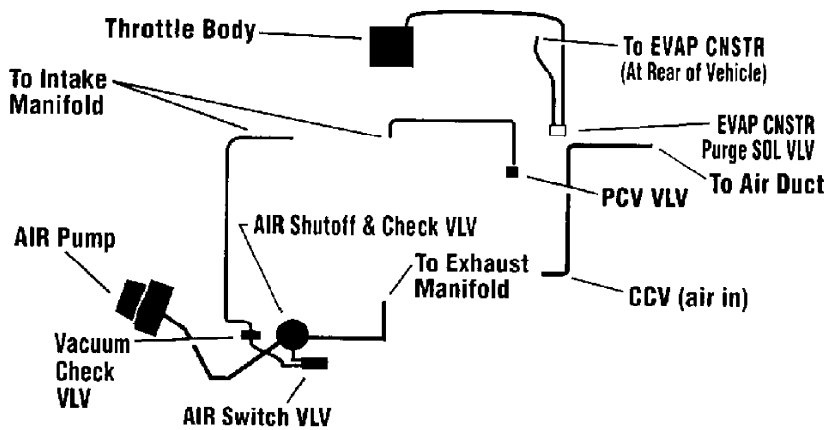

G00023500

Fig. 3: Vacuum Diagram - 1.9L SFI (VIN 7) Saturn "S" Series  
 (California)  
 Courtesy of General Motors Corp.

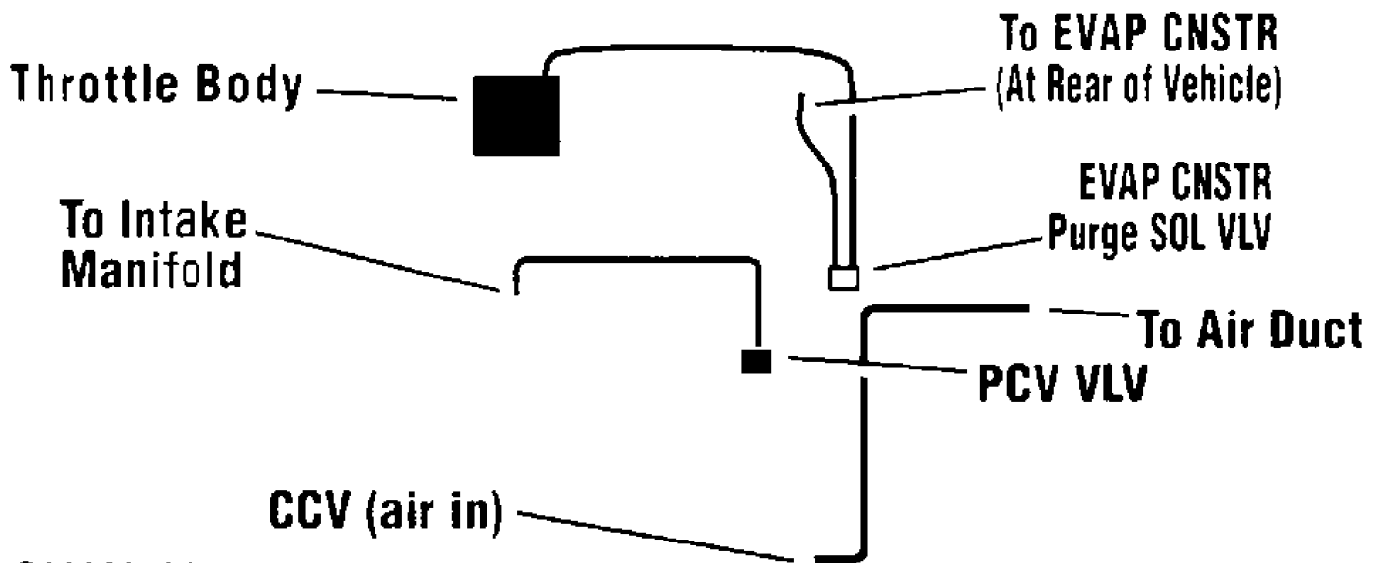

G00023501

Fig. 4: Vacuum Diagram - 1.9L SFI (VIN 7) Saturn "S" Series (Federal)  
 Courtesy of General Motors Corp.

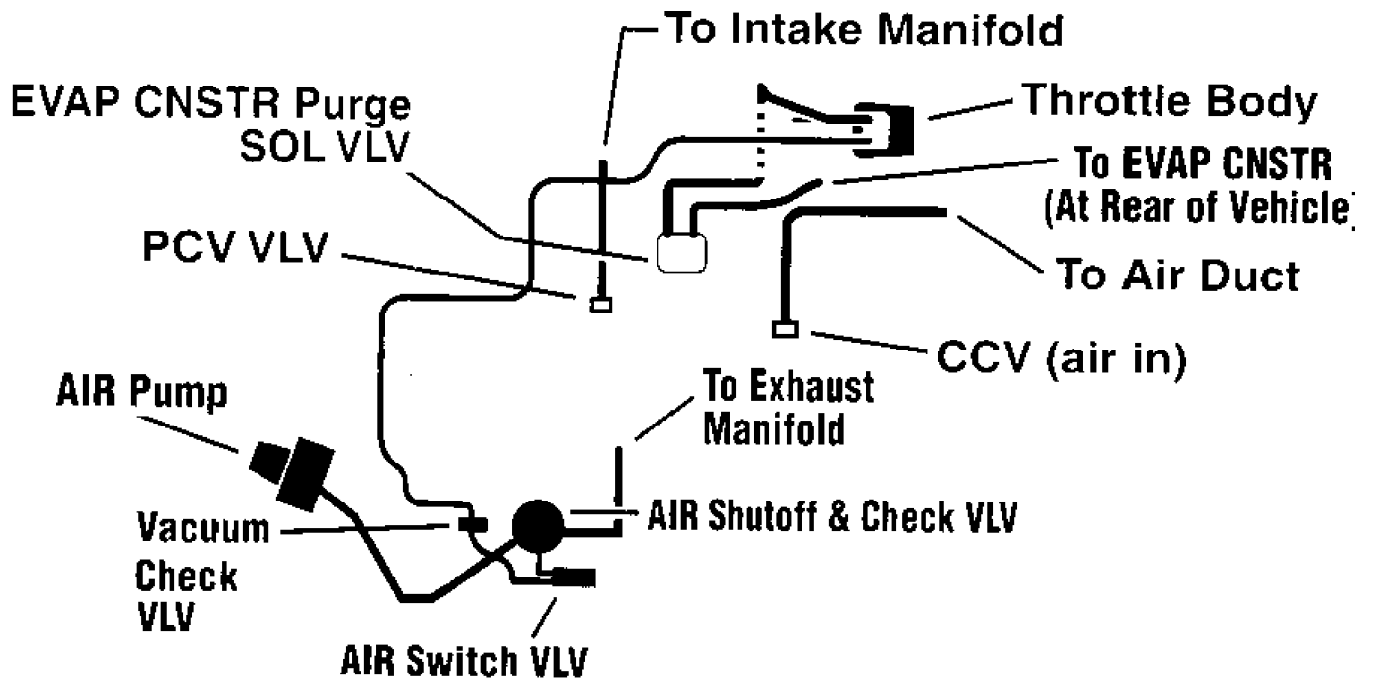

G00023502

Fig. 5: Vacuum Diagram - 1.9L SFI (VIN 8) Saturn "S" Series  
 (California)  
 Courtesy of General Motors Corp.

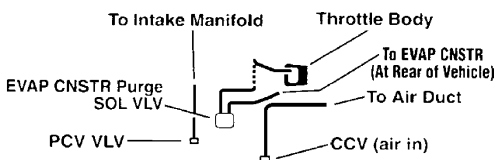

G00023503

Fig. 6: Vacuum Diagram - 1.9L SFI (VIN 8) Saturn "S" Series (Federal)  
 Courtesy of General Motors Corp.

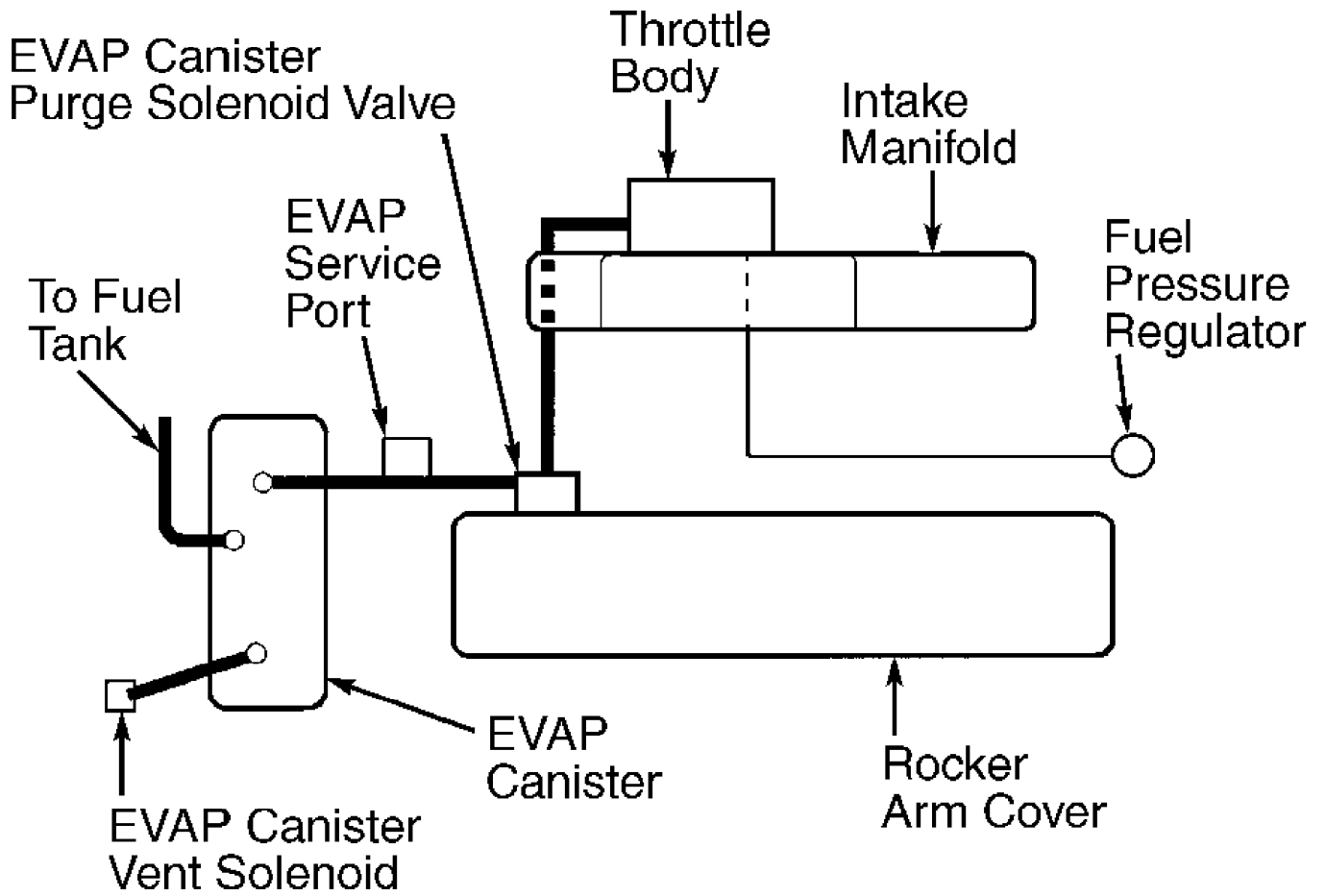

G00012673

Fig. 7: Vacuum Diagram - 2.2L SFI (VIN 4) Cavalier & Sunfire  
 Courtesy of General Motors Corp.

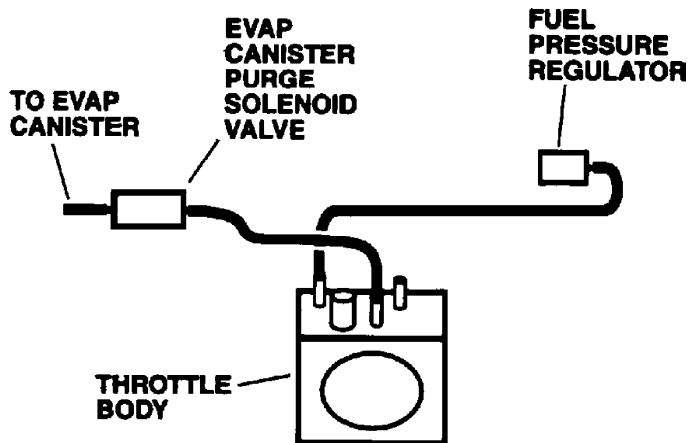

G00023504

Fig. 8: Vacuum Diagram - 2.2L SFI (VIN F) Saturn "L" Series  
 (Except California Emissions)  
 Courtesy of General Motors Corp.

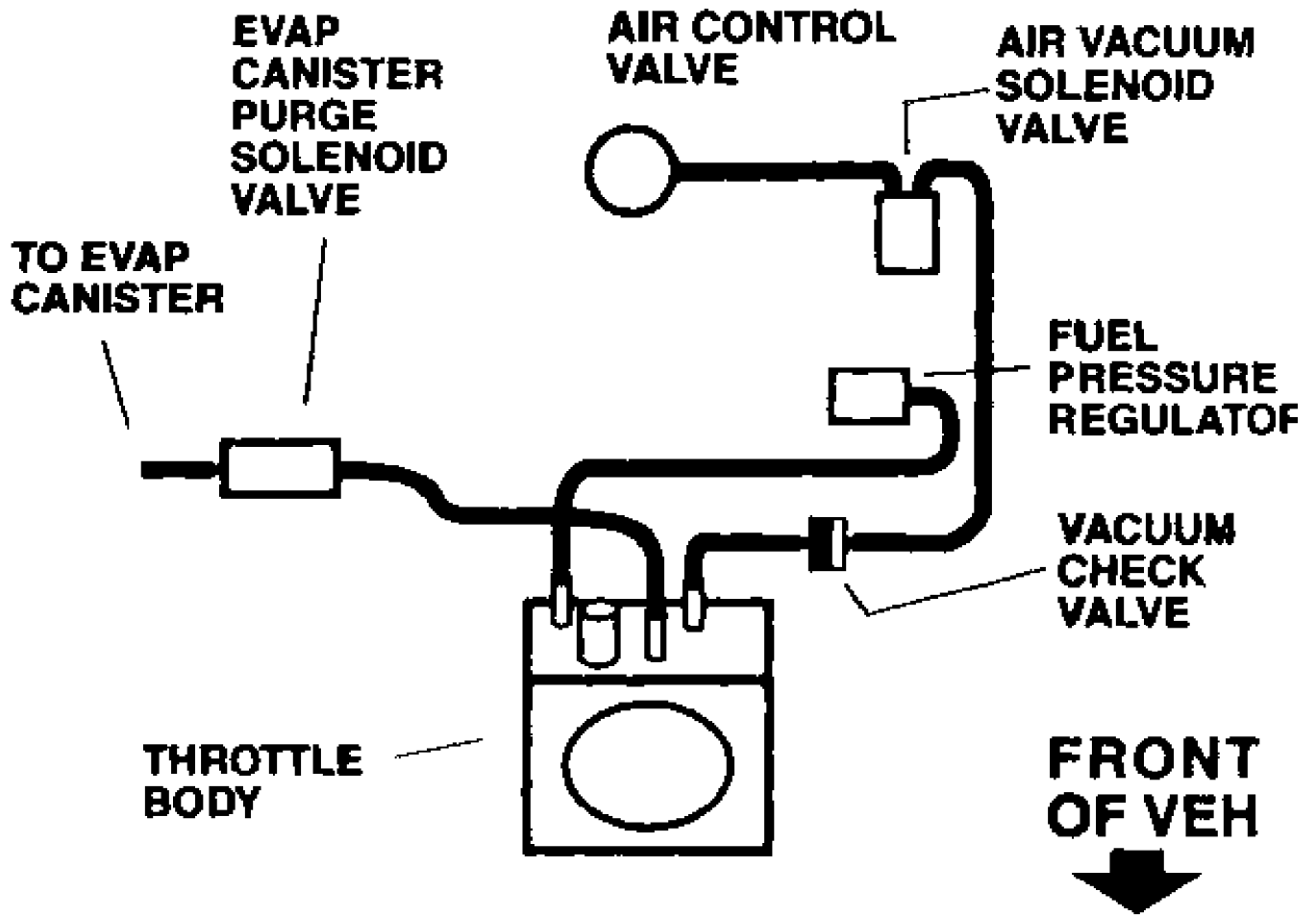

**G00005705**

Fig. 9: Vacuum Diagram - 2.2L SFI (VIN F) Saturn "L" Series (California Emissions)  
 Courtesy of General Motors Corp.

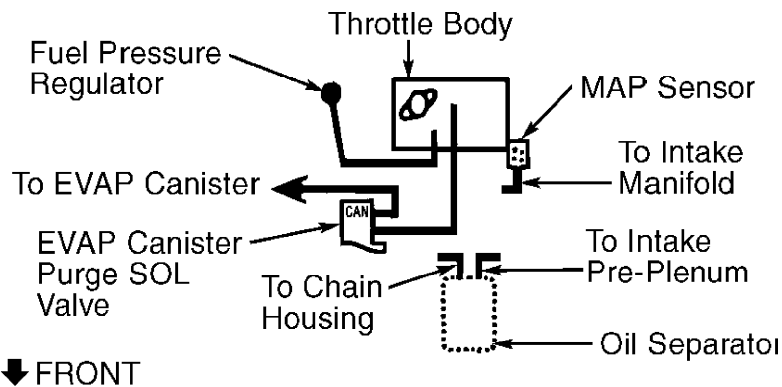

**G98B00266**

Fig. 10: Vacuum Diagram - 2.4L SFI (VIN T) Alero, Cavalier, Grand Am & Sunfire  
 Courtesy of General Motors Corp.

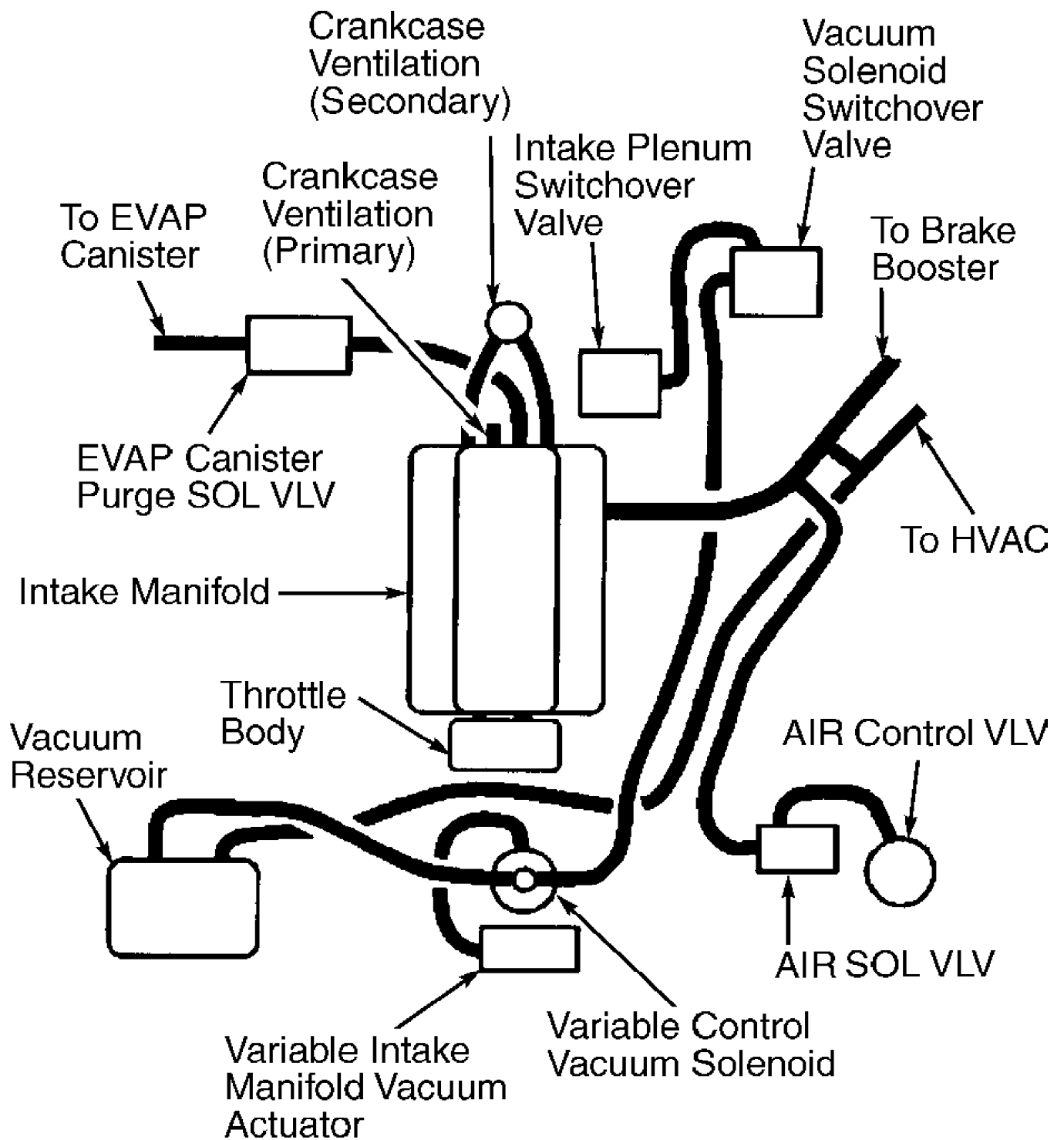

G00012674

Fig. 11: Vacuum Diagram - 3.0L SFI (VIN R) Catera  
 Courtesy of General Motors Corp.

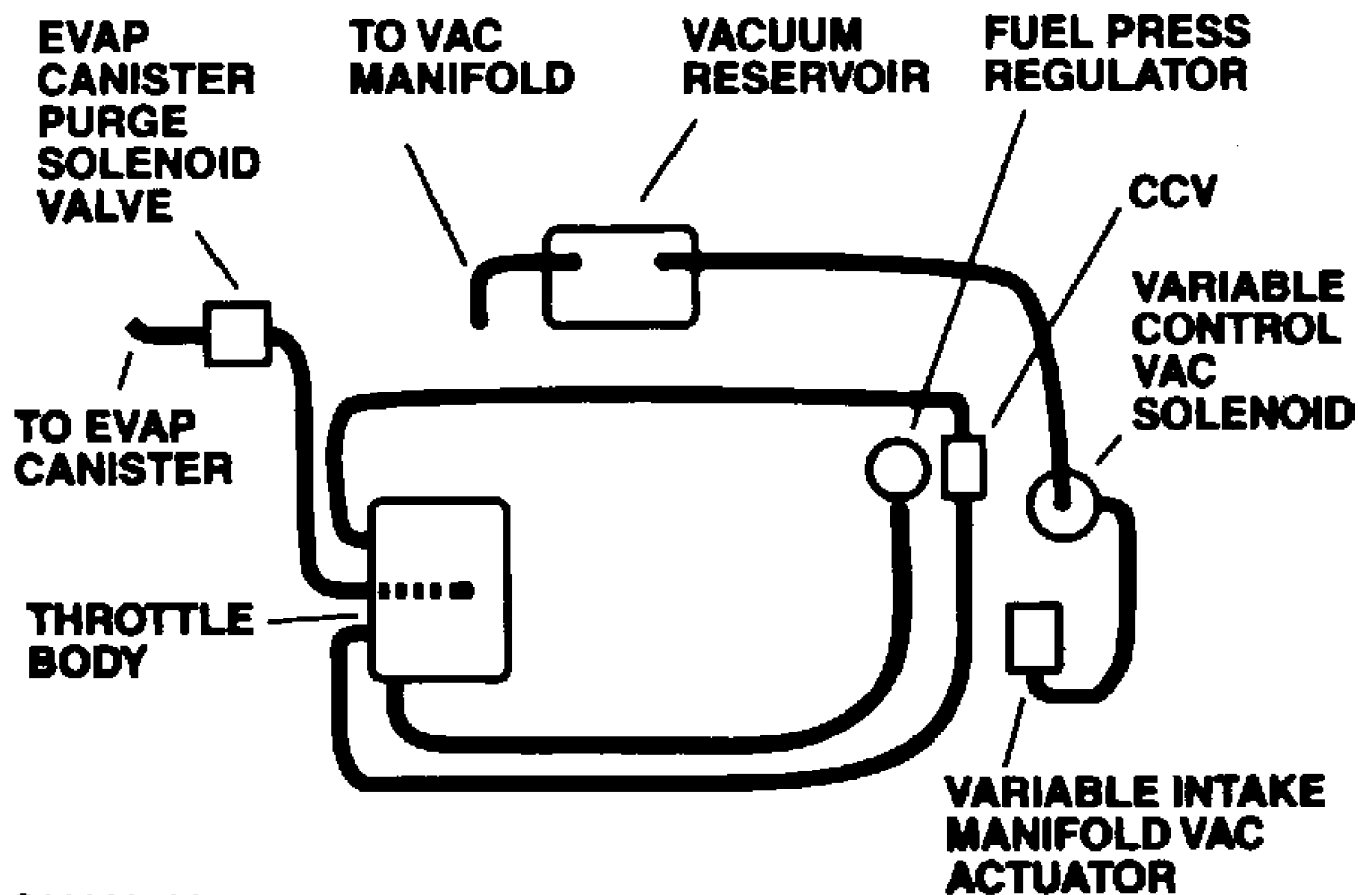

G00023506

Fig. 12: Vacuum Diagram - 3.0L SFI (VIN R) Saturn "L" Series  
 Courtesy of General Motors Corp.

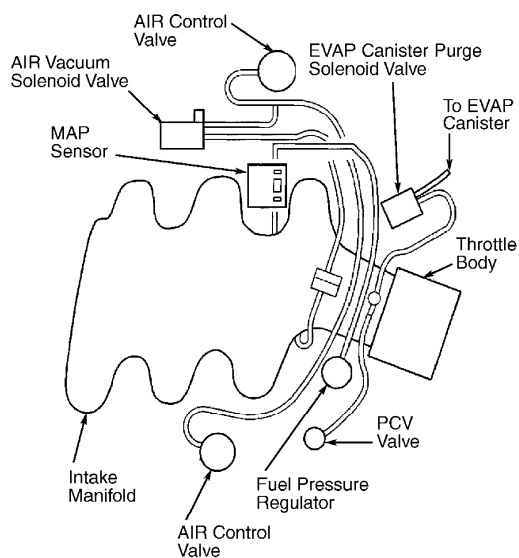

G00005706

Fig. 13: Vacuum Diagram - 3.1L SFI (VIN J) Century, Grand Prix & Malibu, & 3.4L SFI (VIN E) Impala & Monte Carlo  
 Courtesy of General Motors Corp.

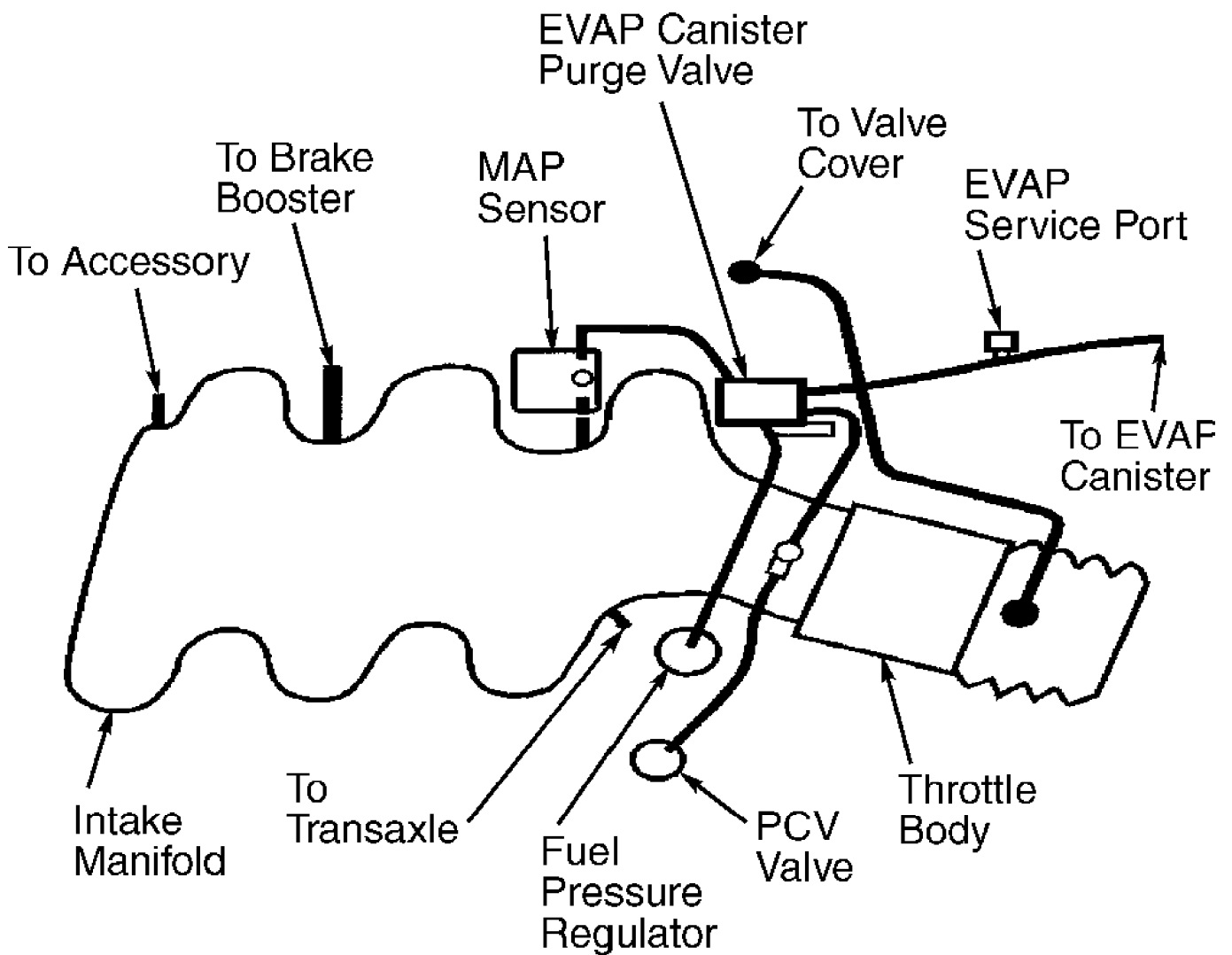

G00005707

Fig. 14: Vacuum Diagram - 3.1L SFI (VIN J) Lumina  
 Courtesy of General Motors Corp.

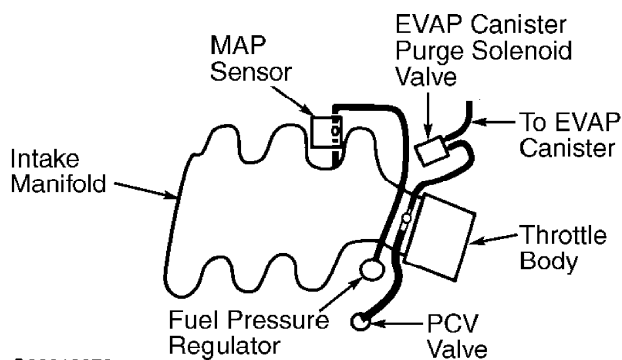

G00012676

Fig. 15: Vacuum Diagram - 3.1L SFI (VIN J) Century, Grand Prix,  
 Lumina & Malibu, & 3.4L SFI (VIN E) Alero, Grand Am, Impala & Monte  
 Carlo (Federal)  
 Courtesy of General Motors Corp.



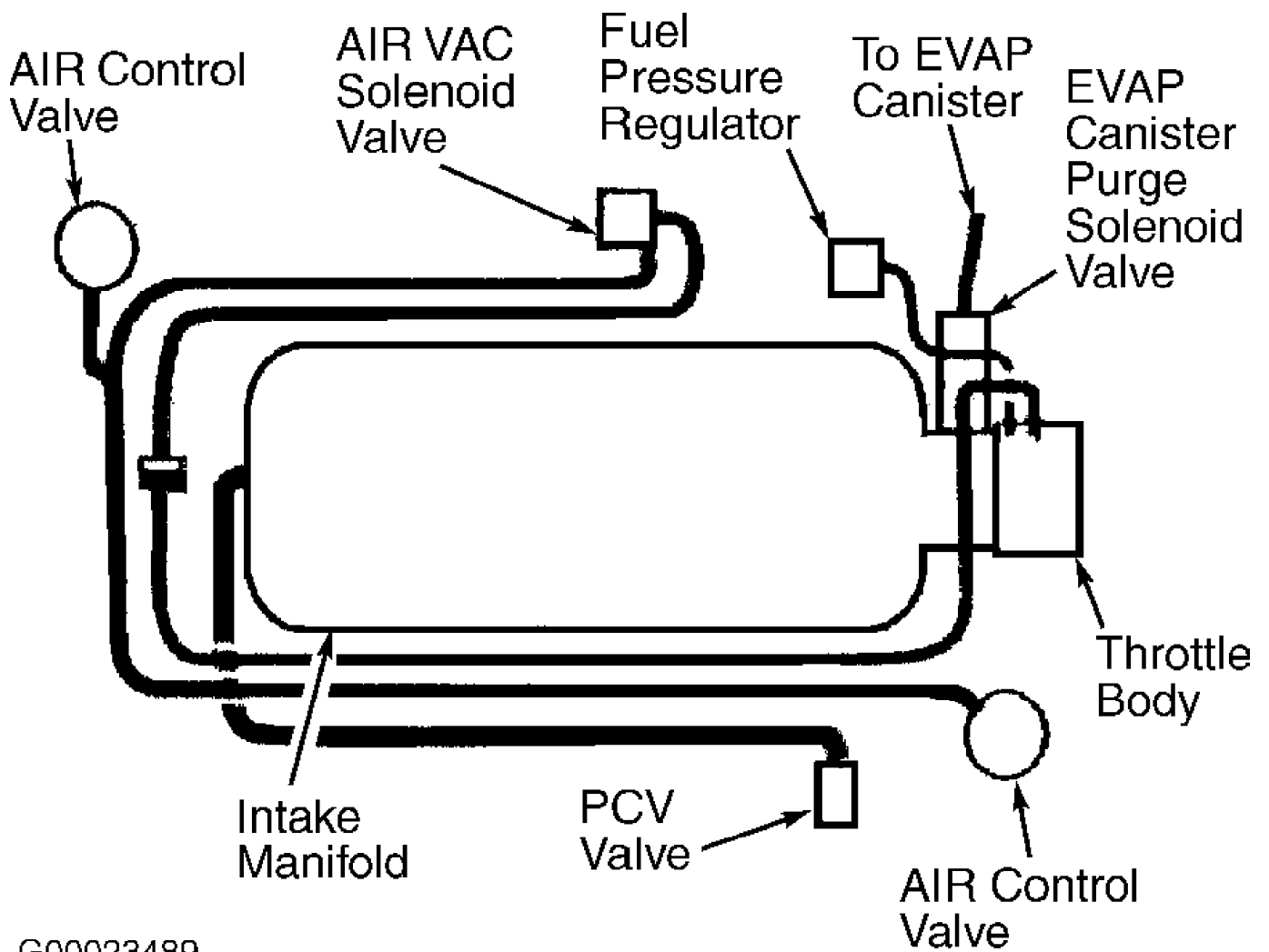

G00023489

Fig. 16: Vacuum Diagram - 3.5L SFI (VIN H) Aurora & Intrigue  
 Courtesy of General Motors Corp.

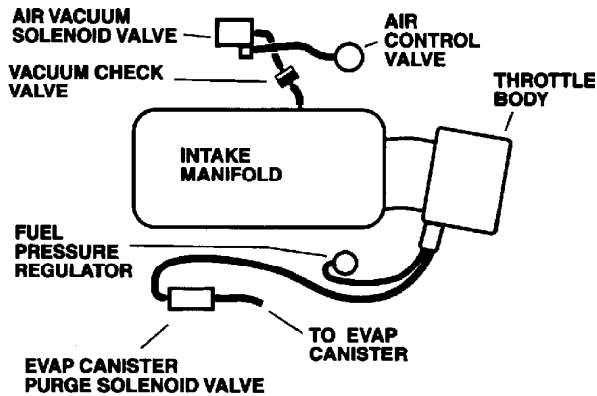

G00023491

Fig. 17: Vacuum Diagram - 3.8L SFI (VIN K) Bonneville, Grand Prix, LeSabre, Park Avenue & Regal  
 Courtesy of General Motors Corp.

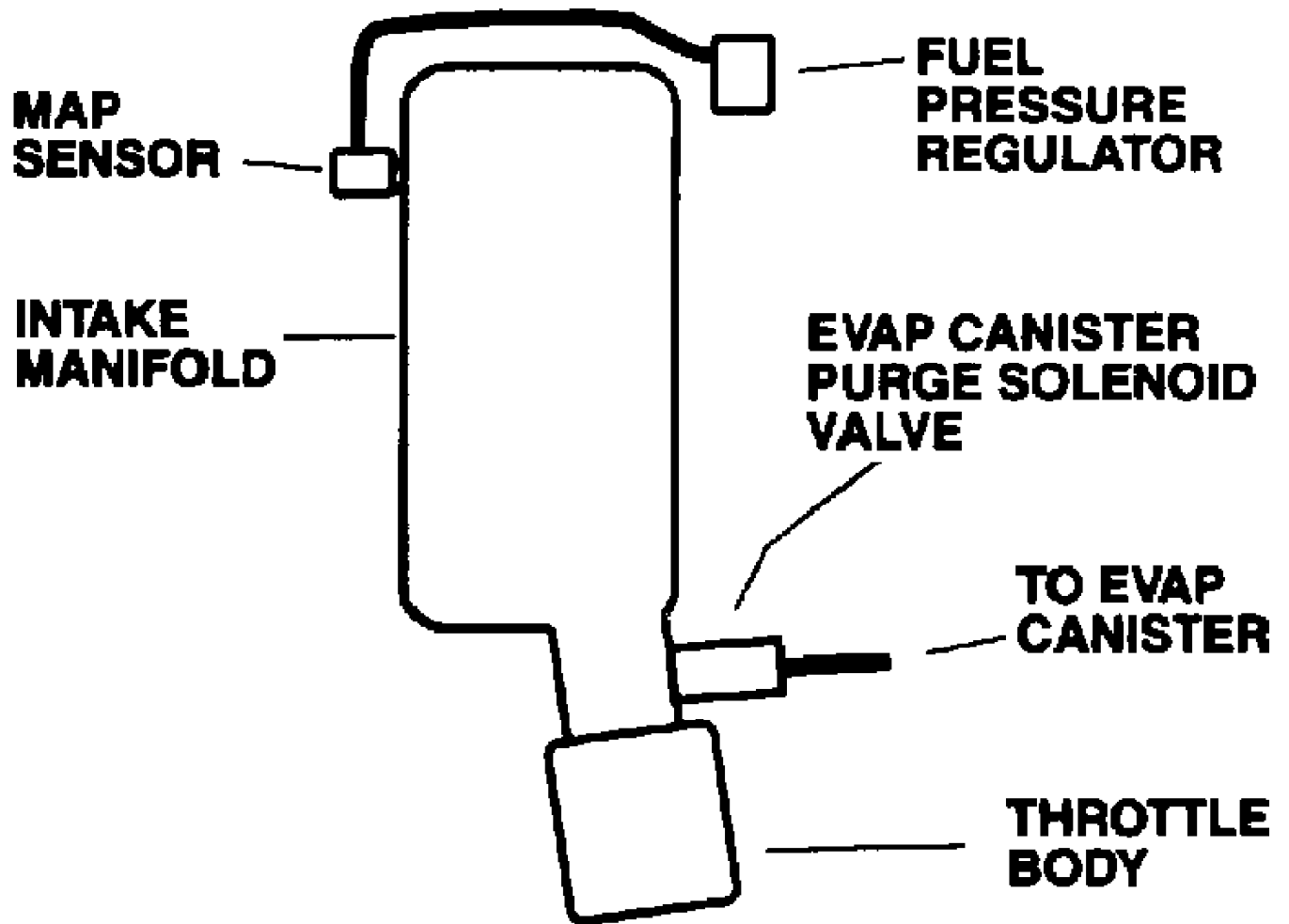

G00023492

Fig. 18: Vacuum Diagram - 3.8L SFI (VIN K) Camaro & Firebird  
 Courtesy of General Motors Corp.

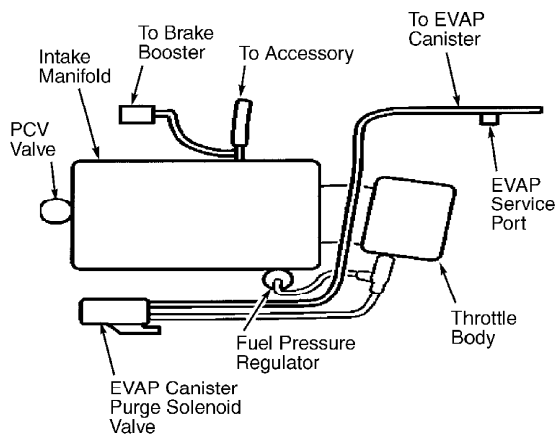

G00005708

Fig. 19: Vacuum Diagram - 3.8L SFI (VIN K) Impala  
 Courtesy of General Motors Corp.

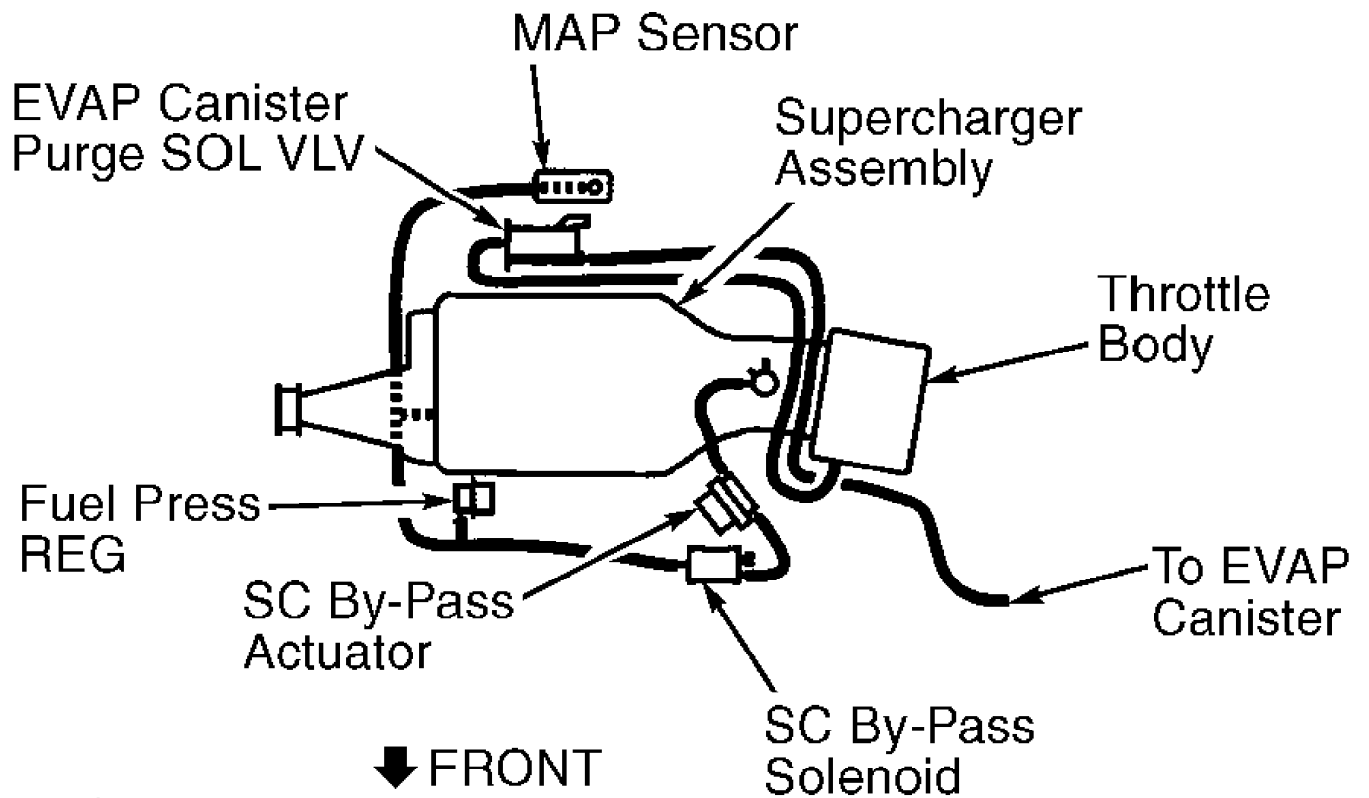

G98J00272

Fig. 20: Vacuum Diagram - 3.8L SFI (VIN 1) Bonneville, Grand Prix, Park Avenue & Regal  
 Courtesy of General Motors Corp.

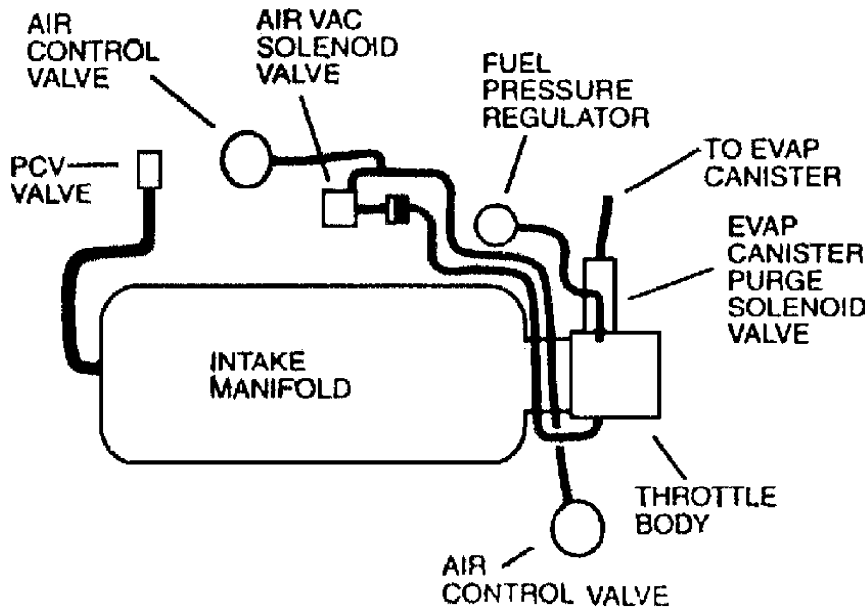

G00023493

Fig. 21: Vacuum Diagram - 4.0L Aurora & 4.6L SFI (VIN Y & 9) DeVille, Eldorado & Seville  
 Courtesy of General Motors Corp.

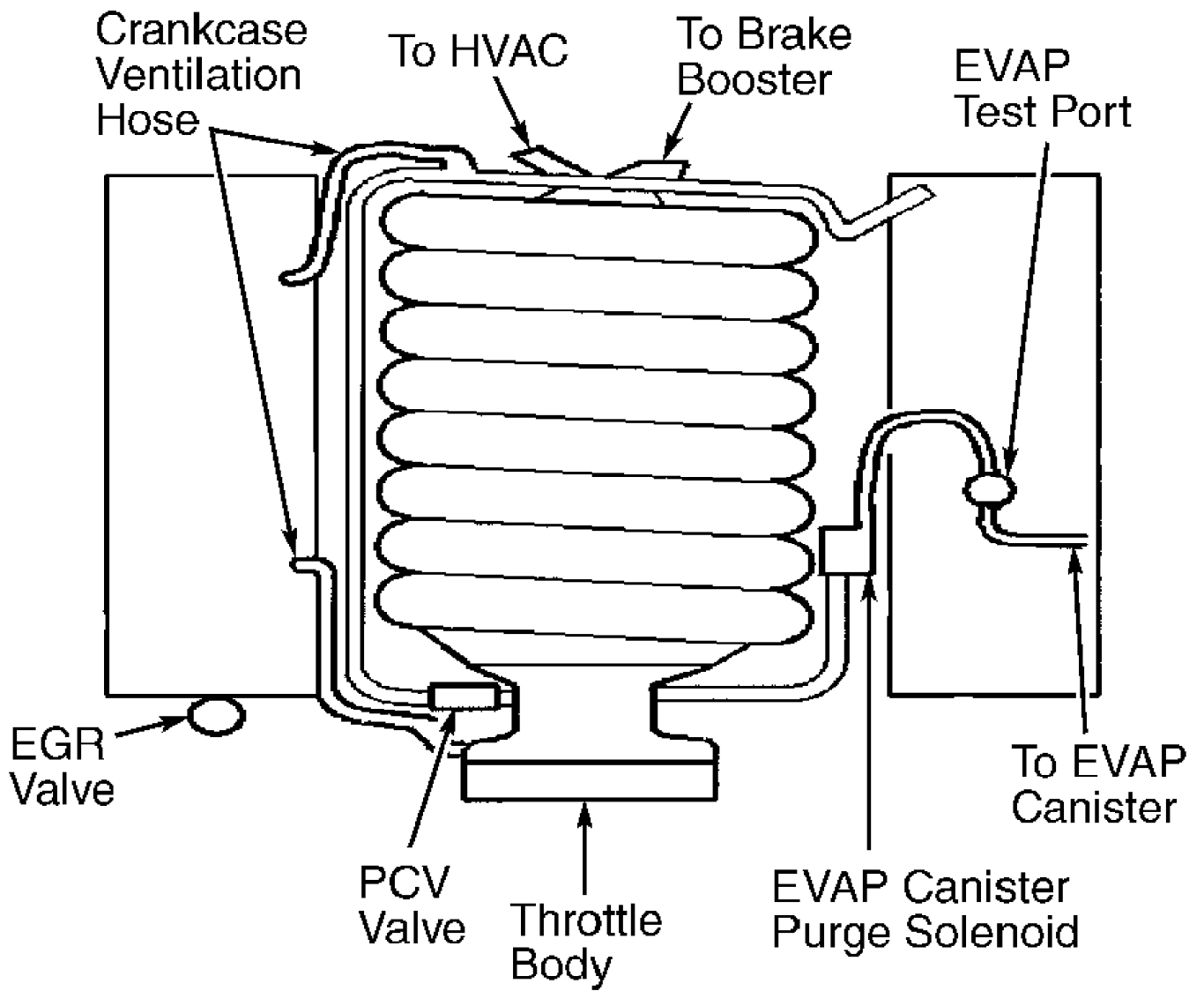

G00005709

Fig. 22: Vacuum Diagram - 5.7L SFI (VIN G) Camaro, Corvette & Firebird  
 Courtesy of General Motors Corp.